

### FEATURES

- Large, high contrast dial face
- Adjustable tolerance markers
- Lockable fine adjustment screw
- Shockproof movement
- Mounting shank and measuring spindle are both made of hardened stainless steel
- Measuring spindle is mounted in a high precision ball guide for minimal hysteresis
- Resistant to lateral forces (side play) acting on the measuring spindle
- Maximum sensitivity and accuracy are ensured by the jeweled movement in conjunction with the precision gears and pinions
- Box type protective housing
- Constant measuring force
- Measuring spindle can be retracted with either a screw in cable release or with a lifting knob
- Package contains: case



### TECHNICAL DATA

Order no.		4334000	4334005	4334102	4334103	4335000	4335005
Product type		1003	1003 T	1002	1003	1002	1002 T
Measuring range	μm	± 50		± 25	± 50		± 25
Graduation value	μm	1		0.5	1		0.5
Type of dial face		50-0-50		25-0-25	50-0-50		25-0-25
Error limit G <sub>e</sub>	μm	1		0.5	1		0.5
Error limit G <sub>ges</sub>	μm	1.2		0.6	1.2		0.6
Error limit G <sub>t</sub>	μm	0.7		0.4	0.7		0.4
Hysteresis f <sub>u</sub>	μm	0.5		0.3	0.5		0.3
Repeatability f <sub>w</sub>	μm	0.5		0.3	0.5		0.3
Standard		DIN 879-1		Factory standard	DIN 879-1		Factory standard
Overtravel	mm					2.8	
Measuring force	N					1	
Scale diameter	mm					50	
Dial color		Yellow		White		Yellow	
IP protection category:		IP 54				IP 54	

Order no.	Mounting shaft	Scale diameter
	mm	mm
4334000	8	50
4334005	8	50
4334102	8	50
4334103	8	50
4335000	8	50
4335005	8	50

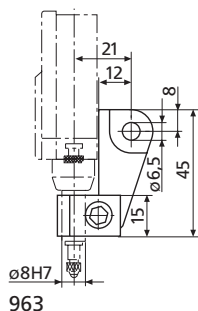
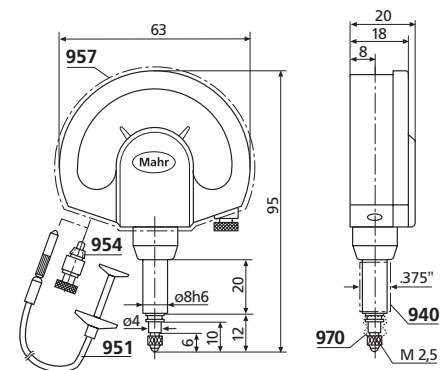

### ACCESSORIES

Order no.	Product name	Product type
4310103	Adapter bushing (.375" / 8 mm)	940
4372000	Cable release (250 mm)	951
4372030	Lifting knob	954
4373030	Splash guard cover	957
4334786	Rubber bellows	970
4375002	Lug back to mount on mounting shank 8h6 mm	963