

FEATURES

- For high-precision measurements
- High-contrast dial face, sealed with O-ring
- Mineral glass viewing panel for best protection:
 - against cracking, scratching or damage caused by hot shavings
 - optimum resistance to solvents
- Matt chrome-plated protective casing with three integrated dovetail guide rails
- Shockproof measuring mechanism
- Anti-magnetic model
- Automatic adjustment to the contacting direction ensuring infallible readings
- Ball bearing mounted double lever
- Friction clutch overload protection
- Package contains: case, instruction manual, spanner for changing the styli, stylus dia. $\varnothing 2$ mm, mounting shaft 800a8



Application:

- Measurement of concentricity, alignment, parallelism and flatness
- Centering of bores and shafts
- Parallel or perpendicular alignment of work pieces

TECHNICAL DATA

Order no.	4308220		
Product type	800 SGE		
Measuring range	mm	± 0.07	
Graduation value	mm	0.001	
Measuring surface	carbide		
Scale diameter	mm	38	
Type of dial face	70–0–70		
Dial color	Yellow		
Measuring force	N	0.2	
Range per rev.	mm	0.14	
Deviation range f_e	μm	3	
Total deviation range f_{ges}	μm	4	
Hysteresis f_u	μm	2	
Partial measuring span f_t	μm	2	
Repeatability f_w	μm	1.5	
Standard	Factory standard		

Order no.	a	c	d	e	f	Measuring anvil length
	mm	mm	mm	mm	mm	mm
4308220	40.5	8.3	12.5	70	94	9.15

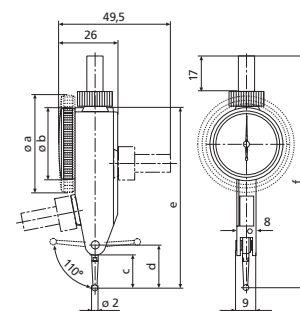

ACCESSORIES

Order no.	Product name	Product type
4308851	Stylus $\varnothing 1.0$ mm, carbide, $l = 9.1$ mm	800 te
4308850	Stylus $\varnothing 2.0$ mm, carbide, $l = 9.1$ mm	800 te
4308852	Stylus $\varnothing 3.0$ mm, carbide, $l = 9.1$ mm	800 te
4309050	Stylus $\varnothing 2.0$ mm, ruby, $l = 9.1$ mm	800 ter
4305868	Spanner	

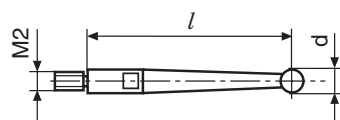

800 tb;800 tbr;800 te;800 ter;800 tl;800 tlr;800 ts;800 tsr;801 tl