



Digimar 817 CLT

Intuitive and ergonomic measurements



Perfect precision

Whether a component completely fulfills its function and continuously delivers the required performance is often dependent on high-precision manufacturing. Height measuring devices from Mahr enable you to measure lengths, distances, diameters, and the perpendicularity of components to the exact micrometer. In addition, measuring results from Mahr height measuring devices can be evaluated easily and quickly in the workshop and laboratory. This prevents malfunctions and downtimes, reduces costs, and ensures your production line remains running in the long-term.

- Outstanding measurement accuracy and the highest level of precision
- Extremely easy to transfer data
- Suitable for workshops and laboratories
- Best ergonomics

Contents

Digimar 817 CLT

Easy measurements using intuitive touch control



Products | Page 4

**Ergonomics that
can be measured**

Info | Page 6

**Simple touch
measurement**

Info | Page 8

Technical data

Info | Page 10

Accessories

Accessories | Page 11

Easy measurements using intuitive touch control

With the new height measuring device Digimar 817 CLT you can measure components in no time at all. A pivotable touch display ensures that the Digimar 817 CLT is as easy to operate as a tablet. Large buttons, clearly structured menus, and self-explanatory icons ensure tasks can be completed quickly and efficiently while also reducing the number of mistakes. Function keys on the side and a thumbwheel make it easy to position the measuring slide and start the measurement. Handles on both sides and the integrated air bearing guarantee that you can accurately and easily move your device on the measuring plate. The new height measuring device is available in three measuring ranges: 350, 600 and 1,000 mm.

Advantages:

- Intuitive and easy to operate via touch display without the need of extensive training
- Pivotable and tiltable display provides a relaxed working environment
- Air bearing system and handles on both sides ensure easy and smooth movement
- Function keys and a dynamic thumbwheel make it faster and easier to operate
- Powerful battery for independent operation for up to two shifts

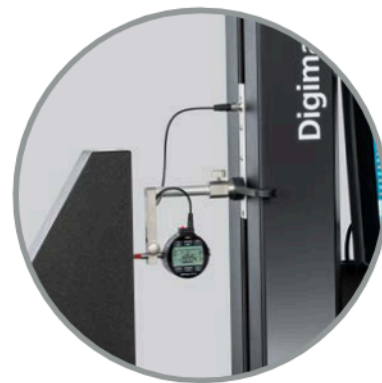

Interfaces for dial indicators

An interface integrated in the slide enables the error-free measurement of the perpendicularity and straightness using the new digital comparators Millimes 2000/2001 W, illustrated on page 13.

Best ergonomics

Ergonomic handles on both sides have an integrated operating key for the air bearing ensuring the device can be moved accurately and effortlessly on the measuring plate.



Best connection for secure data

The Digimar 817 CLT has a variety of interfaces available to save your measuring data. Data can be transferred wirelessly or via USB cable via the MarConnect interface. Quickly print out a series of measurements? The Star Micronics SM-L200 Bluetooth® printer is available for this purpose. Simply choose between complete measuring records in PDF format or save your measuring records as a TXT file.



Pivoting display

The 10-inch touch panel with turn/tilt joint enables it to be set individually based on the work position, height of the operator, and lighting conditions.

Easy handling

The thumbwheel can be used to quickly move the measuring slide and start measurements easily. The quick measurement function keys also automatically detect surfaces and bores.

Ergonomics that can be measured

Ergonomics means that the methods, processes, and arrangement are designed for people and not the other way around. This is exactly what the new Digimar 817 CLT stands for: The simple moving and scrolling functions of the touchscreen work just like your smartphone and tablet. The keys on the display are already arranged in such a way that frequently used functions are particularly easy to access. The measurements on the measuring slide can easily be started by hand via the touch display, the thumbwheel with integrated arrow keys, or using Quick Mode. Two pushbuttons to actuate the air bearings are integrated into the handle, enabling the device to be guided safely and sensitively by left and right-handed operators. Regardless of whether you prefer to sit or stand while working: The touch display is always at eye level and can be rotated and tilted as required. This ensures the measuring process is particularly comfortable and relaxed.

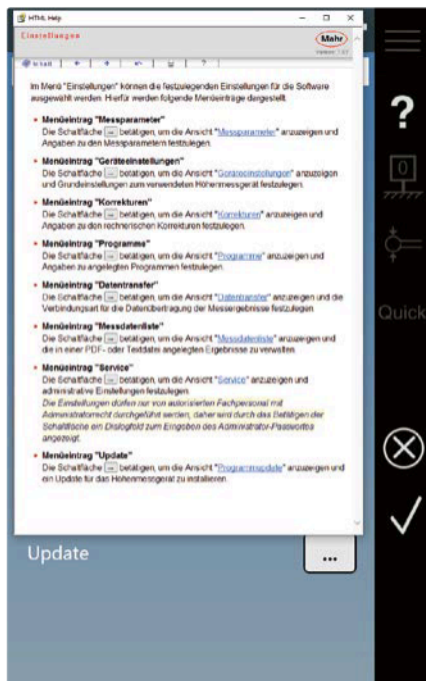

The interactive online instructions provide a simple and fast overview of all the measurement and setting functions.

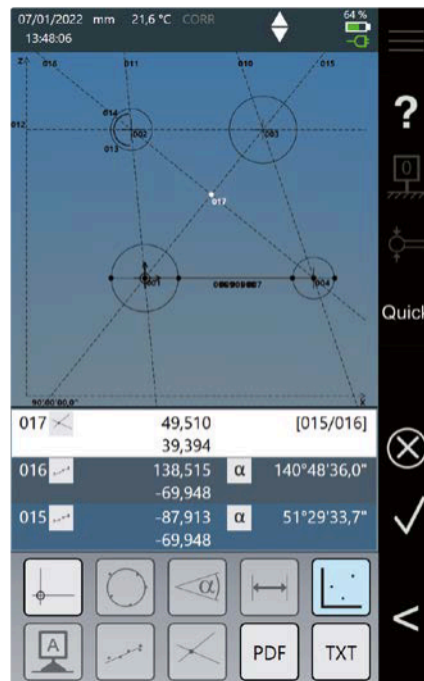

Complex tasks, such as 2D measurements and evaluations, are also easy to complete.



1 The large keys and clear structure ensure that the 10-inch touch panel is easy to operate.



2 The ergonomic thumbwheel and function keys enable operators to easily and quickly position the measuring probe and to start the measurement. For very large workpieces an air bearing, that is activated via keys in the handle, supports the exact positioning of the device.



3 The universal swivel arm can be used to adjust the control panel to the best working position for the individual thus ensuring optimum usability.

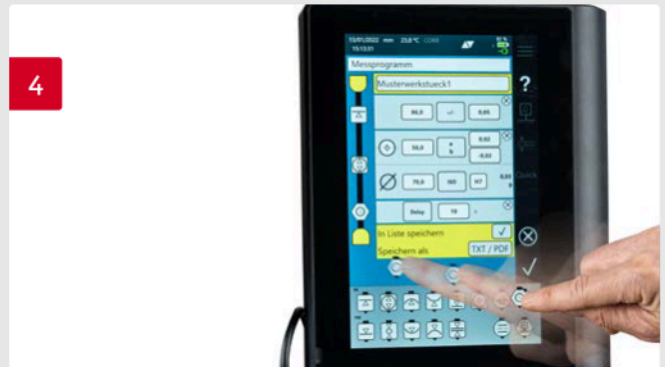

4 Simple Drag & Drop tasks and saved ISO tolerance tables make it very easy to create measuring programs.

Simple touch measurement

The new Digimar 817 CLT is intuitive to operate via large clearly defined keys. This always ensures the safe completion of measurements, setting and calculation functions, and the creation of measuring programs via Drag & Drop.

Uncluttered

The large measured value display provides a clear overview.

Clear

The measuring value list scores highly for its clear and unambiguous description.

Touch & Go

Large touch keys take the user directly to the measuring and evaluation functions.



One solution, many advantages

- Clearly structured display
- Extensive measurement and calculation functions
- Extended 2D display and calculation functions
- Automatic perpendicularity and straightness measurement (with accessories)
- Automated measuring sequences, simply created via Drag & Drop or teach-in
- Available in 12 languages

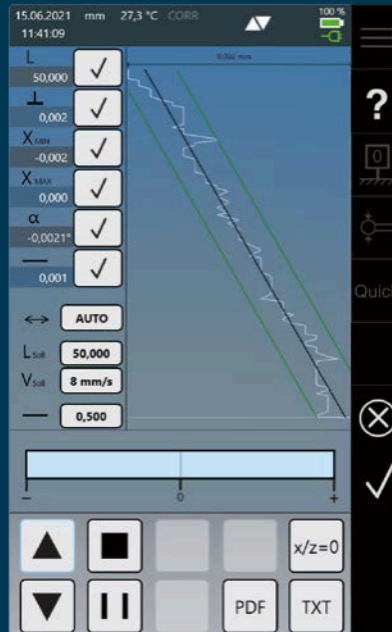

Easily select

Distances, symmetries, etc. can be calculated very easily by selecting the measured values in the measuring value list via the touchscreen.



Access important functions quickly

Setting, measuring, and special measuring functions can be called up via Quick Access.

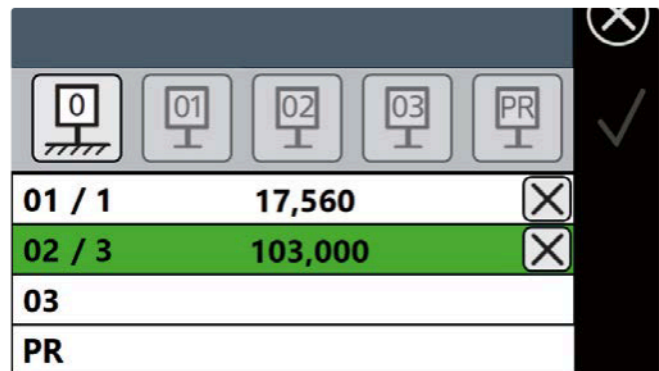

Changing parameters

Reference points can be changed quickly and easily.

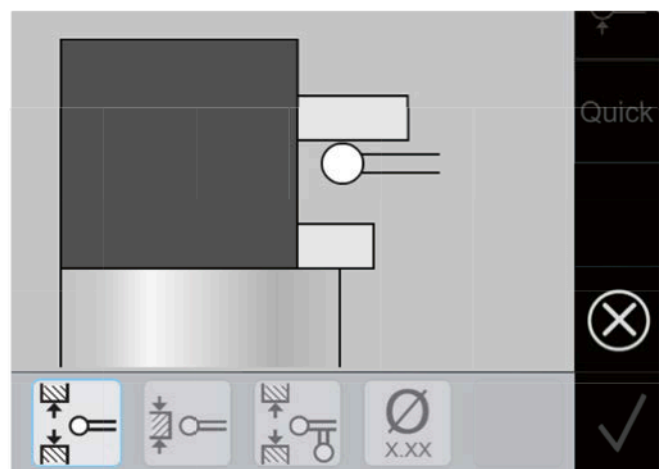

Smarter support

The screen animation supports the probes during calibration.

Device information

Digimar 817 CLT

Item no. 4429600 | 4429601 | 4429602

- A: 89.2 mm
 B: 278 mm
 C: 77 mm
 D: 255 mm
 E: 688 mm | 938 mm | 1,338 mm

Measuring range

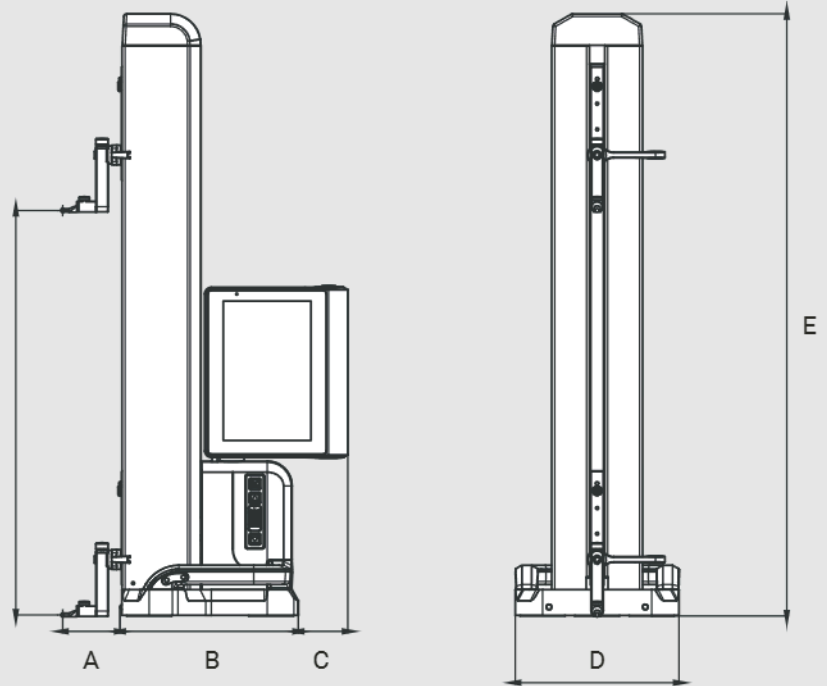

Item no.	4429600	4429601	4429602
Measuring range	0 – 350 mm	0 – 600 mm	0 – 1,000 mm
Extended application range of		170 mm	
Extended application range up to	520 mm	770 mm	1,170 mm
Resolution	0.01 mm, 0.005 mm, 0.001 mm, 0.0005 mm, 0.0001 mm .001", .0005", .0001", .00005", .00001"		
Error limit	$(1.8 + L/600) L$ in mm		
Repeatability planes	0.5 µm		
Repeatability bores	1 µm		
Perpendicularity deviation	5 µm	6 µm	10 µm
Operating time max.	14 h		
Measuring force	1.0 +/- 0.2 N		
Rel. humidity, non-condensing	65 %		
Working temperature	20 °C		
Operating temperature	10 – 40 °C		
Product weight	22 kg	26 kg	29 kg
Data interface	USB, Wireless		
Standard	Factory standard		

Useful additions for every measuring task

The accessories provided with a measuring instrument can considerably expand your options as they offer additional or more accurate measuring options for your device. Contact your metrology expert for advice.

Carriers and holders for measuring inserts

Solve measuring tasks quickly and elegantly with the comprehensive range of mounts and holders that can be combined with various measuring anvils.

Order no.	Description	Type	Holder	Application
4429154	Carrier	817 h1	∅ 6 mm	universal
4429219	Carrier	817 h2	∅ 6 mm	for large measuring depths
4429220	Carrier	817 h4	∅ 8 mm	universal
4429454	Carrier with pivoting holder	817 h5	∅ 6 mm	combined with the cylinder keys
3015917	Probe holder	Gk/8	M3 / ∅ 4 mm	for delicate workpieces
4429256	Probe holder incl. measuring anvil ∅ 2.0 mm	KM 2	M2	for delicate workpieces

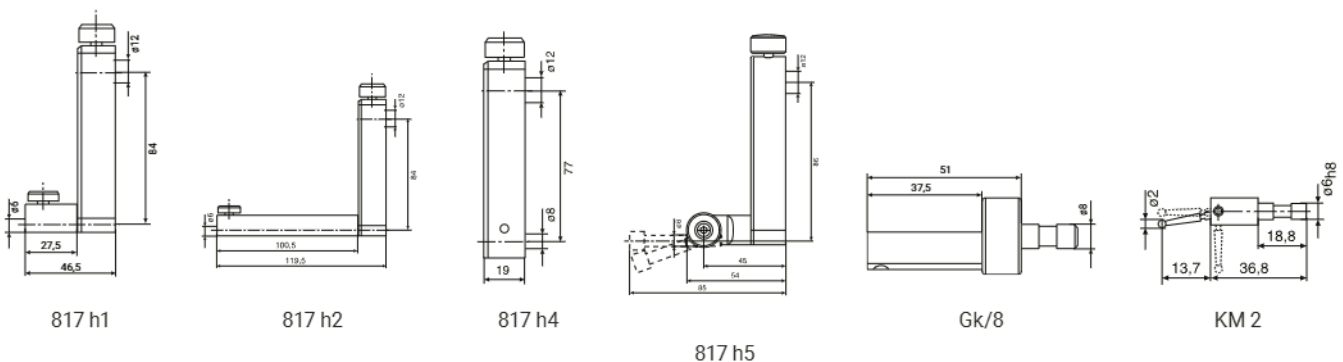

Spherical anvils

The use of spherical anvils is particularly common as they can be used for nearly all standard measuring tasks. Mahr supplies probes in many lengths and sphere diameters and thus guarantees to have the right solution for your measuring task.

Digimar 817 CLT

Order no.	Description	Type	Holder	Suitable for carrier/holder
4305870	Measuring anvil \varnothing 1.0 mm, carbide, l = 14.5 mm	800 ts	M2	KM 2, TMT 120, TMT 120 S
4305850	Measuring anvil \varnothing 2.0 mm, carbide, l = 14.5 mm	800 ts	M2	KM 2, TMT 120, TMT 120 S
4305871	Measuring anvil \varnothing 3.0 mm, carbide, l = 14.5 mm	800 ts	M2	KM 2, TMT 120, TMT 120 S
4309051	Measuring anvil \varnothing 2.0 mm, ruby, l = 14.5 mm	800 tsr	M2	KM 2, TMT 120, TMT 120 S
3022002	Spherical probe, dk = 1.0 mm, l = 24 mm, carbide	K1/24	M3	Holder Gk/8
3022001	Spherical probe, dk = 2.0 mm, l = 24 mm, carbide	K2/24	M3	Holder Gk/8
3022000	Spherical probe, dk = 3.0 mm, l = 24 mm, carbide	K3/24	M3	Holder Gk/8
4429158	Spherical anvil, \varnothing 5.0 mm, carbide	K5/51	\varnothing 6 mm	Carrier 817h1/-h2/-h5
4429254	Spherical anvil, \varnothing 6.0 mm, carbide	K6/31	\varnothing 6 mm	Carrier 817h1/-h2/-h5
7023813	Spherical anvil, \varnothing 4.0 mm, carbide	K4/30	\varnothing 8 mm	Carrier 817 h4
7023816	Spherical anvil, \varnothing 6.0 mm, carbide	K6/40	\varnothing 8 mm	Carrier 817 h4
7023810	Spherical anvil, \varnothing 10.0 mm, carbide	K10/60	\varnothing 8 mm	Carrier 817 h4
7023815	Spherical anvil, \varnothing 10.0 mm, carbide	K10/100	\varnothing 8 mm	Carrier 817 h4

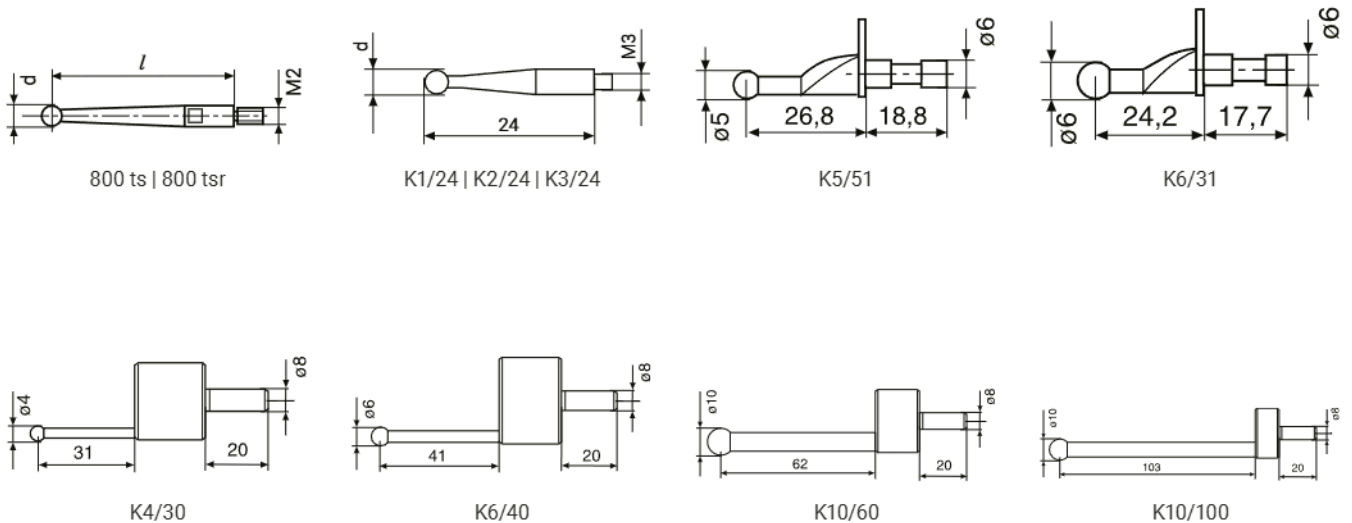

Disc and cylindrical measuring anvils

Disc measuring anvils are your best option of measuring equipment when it comes to measuring tapered and groove diameters. Cylindrical measuring anvils, on the other hand, are particularly used for the measurement of tapers combined with holder 817 h5 and the measurement of features with small contact surfaces.

Order no.	Description	Type	Holder	Suitable for carrier/holder
4429226	Disc measuring anvil \varnothing 15 mm	S15/31,2	\varnothing 6 mm	Carrier 817h1/-h2
4429227	Cylinder measuring anvil \varnothing 10 mm	Z10/31,2	\varnothing 6 mm	Carrier 817 h5

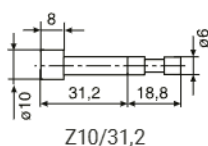
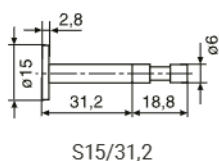

Conical measuring anvils

Conical measuring anvils will help you to quickly and easily determine the center points of holes especially when it comes to thin-walled workpieces, such as metal sheets.

Order no.	Description	Type	Holder	Suitable for carrier/holder
4429228	Tapered anvil	MKe 30	\varnothing 6 mm	Carrier 817h1/-h2
3015920	Tapered anvil	MKe 8	M3	Holder Gk/8

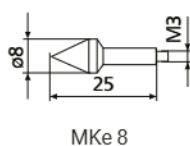
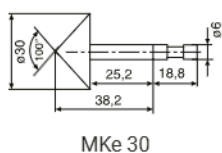

Accessories for perpendicularity measurements

Automatically measure and document the perpendicularity and straightness of workpieces: This is very easy to achieve with the digital comparator from Mahr that can be connected to the Digimar 817 CLT.

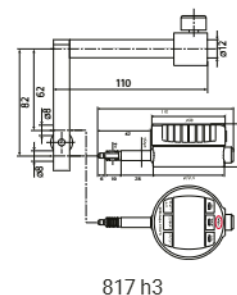

Order no.	Description	Type	Holder	Suitable for
4429206	Holder for perpendicularity measurement	817 h3	\varnothing 8 mm	Comparators and dial indicators
4429610	Data connection cable	DK-M1		2000 W / 2001 W
4346700	Digital comparator 0.00001 mm / \pm 2 mm	2000 W	\varnothing 8 mm	–
4346800	Digital comparator 0.00001 mm / \pm 2 mm	2001 W	\varnothing 8 mm	–

Depth probes

Do your measuring tasks include the measurement of distances between grooves or the depth of blind holes? Then the depth probes from Mahr are exactly the right tool for you.

Order no.	Description	Type	Holder	Suitable for carrier/holder
4429221	Depth probe	TMT 120	∅ 6 mm	–
4429421	Depth probe, pivotable	TMT 120 S	∅ 6 mm	–
3015918	Probe shoe, d = 0.5 mm, l = 78 mm	TS 0,5/78	∅ 4 mm	Holder Gk/8
3015919	Stylus/stylus tip, d = 1.2 mm, l = 75 mm, ls = 15.5 mm	T 1,2/75	∅ 4 mm	Holder Gk/8
4429256	Probe holder incl. measuring anvil ∅ 2.0 mm	KM 2	M2	Träger 817h1/h2

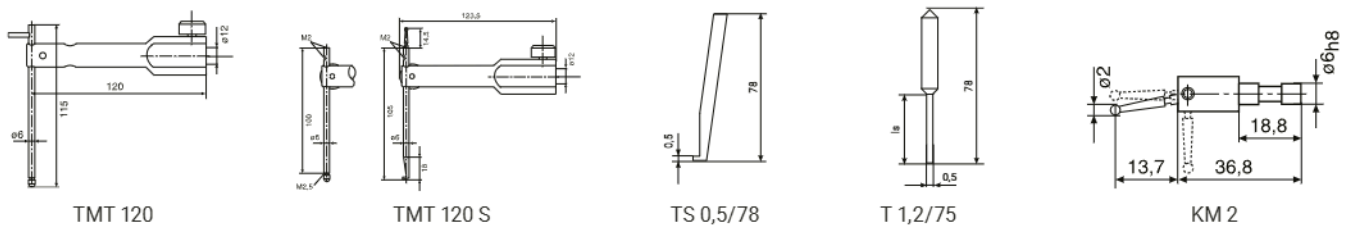

Other accessories

From the printer set through to the USB adapter and from the test plate to the subframe, Mahr has a range of accessories that will make it easier for you to complete your measuring tasks.

Order no.	Description	Type
6910271	Set consisting of Star Micronics SM-L200 Bluetooth® printer and USB wireless adapter	DP-B1
5450105	Printer paper, 12 rolls	–
4102220	USB adapter for MarConnect Wireless	i-stick
4221525	Test plate made of granite, 1,000 x 630 mm	107 G
4221573	Safety frame, 1,000 x 630 mm	107 Ug
4221526	Test plate made of granite, 1,200 x 800 mm	107 G
4221574	Safety frame, 1,200 x 800 mm	107 Ug



i-Stick



107 G + 107 Ug



DP-B1

Accessory sets

The following accessory sets are also available for your individual measuring tasks:

Order no.	Description	Type	Probe replacement 817 ts1 Item no. 4429019	Probe replacement 817 ts2 Item no. 4429018	Probe replacement 817 ts3 Item no. 703400
4429219	Carrier	817 h2	x	x	
4429220	Carrier	817 h4	x	x	
3015917	Probe holder	Gk/8			x
4429256	Probe holder incl. measuring anvil \varnothing 2.0 mm	KM 2	x	x	
7023813	Spherical anvil, \varnothing 4.0 mm	K4/30	x		
7023816	Spherical anvil, \varnothing 6.0 mm	K6/40	x		
7023810	Spherical anvil, \varnothing 10.0 mm	K10/60	x		
7023815	Spherical anvil, \varnothing 10.0 mm	K10/100	x		
3022002	Spherical probe, dk = 1.0 mm, l = 24 mm, carbide	K1/24			x
3022001	Spherical probe, dk = 2.0 mm, l = 24 mm, carbide	K2/24			x
3022000	Spherical probe, dk = 3.0 mm, l = 24 mm, carbide	K3/24			x
4429226	Disc measuring anvil \varnothing 15 mm	S15/31,2	x	x	
4429227	Cylinder measuring anvil \varnothing 10 mm	Z10/31,2	x	x	
4429228	Tapered anvil	MKe 30	x	x	
3015918	Probe shoe, d = 0.5 mm, l = 78 mm	TS 0,5/78			x
3015919	Stylus/stylus tip, d = 1.2 mm, l = 75 mm	T 1,2/75			x
4429221	Depth probe	TMT 120	x	x	x
3015921	Extension M3 – M3, l = 20 mm	V/M3			x
3015888	Extension M3 – M2.5, d = 4 mm, l = 20 mm	V/M2,5			x



817 ts1



817 ts2



817 ts3



Mahr GmbH
Carl-Mahr-Straße 1
37073 Göttingen
Germany

Reutlinger Straße 48
73728 Esslingen
Germany

Phone: +49 551 7073 800
info@mahr.com
www.mahr.com

© **Mahr** GmbH

We reserve the right to make changes to our products,
especially due to technical improvements and further developments.
All illustrations, numerical values, etc. are therefore subject to change.

3765872 | 11.2024