

# SIGMA

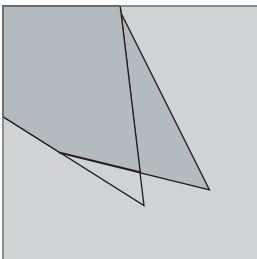

## | SIGMA



Extremely positive rake angle

A blade especially for stainless and acid-resistant steels, whose high cutting performance leads to excellent results. The cutting resistance is considerably reduced thanks to the use of a patented tooth geometry in conjunction with an extremely positive rake angle.

### Properties

- M42 HSS steel with 8% cobalt
- extremely positive rake angle
- sectional cut channel
- SMARTCUT version available (41 x 0.9 mm)

### Advantages

- aggressive cutting behaviour for long-chipping materials
- reduces negative effects such as strain hardening
- Reduction of the cutting resistance
- Highest performance even with aluminium alloys

# SIGMA

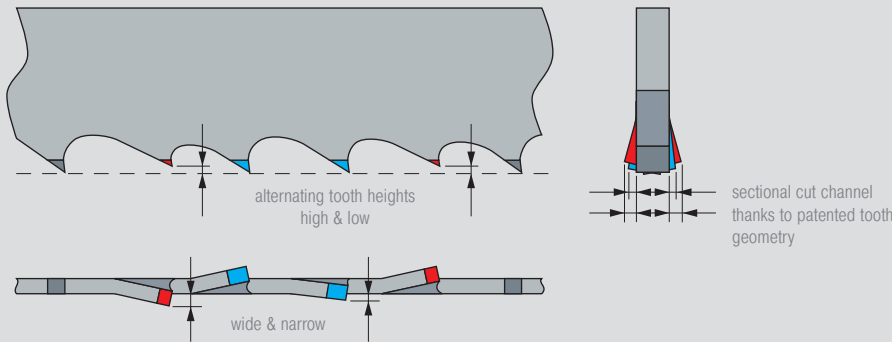

Sectional cut channel

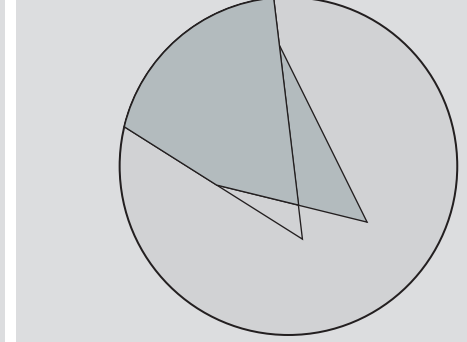

Extremely positive rake angle



## Application materials – AMADA Sigma

Recommended	Suitable	Limited suitability*
Hot-working steel, stainless steel, high heat-resisting steel, aluminium alloys, plastics	Nickel alloys, copper alloys	Cold work steel, titanium alloys

Cold-worked steel



Hot-working steel



Stainless steel



High heat-resisting steel



Aluminium alloys



Nickel alloys



Titanium alloys



Copper alloys



## Selection of the tooth pitch – AMADA Sigma delivery forms

Height	Thickness	0.75/1	1.1/1.5	1.5/2	2/3	3/4
27	0.9					•
34	1.1				•	•
41	0.9				•	•
41	1.3			•	•	•
54	1.6		•	•	•	
67	1.6	•	•	•		
80	1.6		•			

Recommended run-in surface: 0.1 m<sup>2</sup>

\* With respect to application notes, please consult your AMADA sales representative