

serie HT

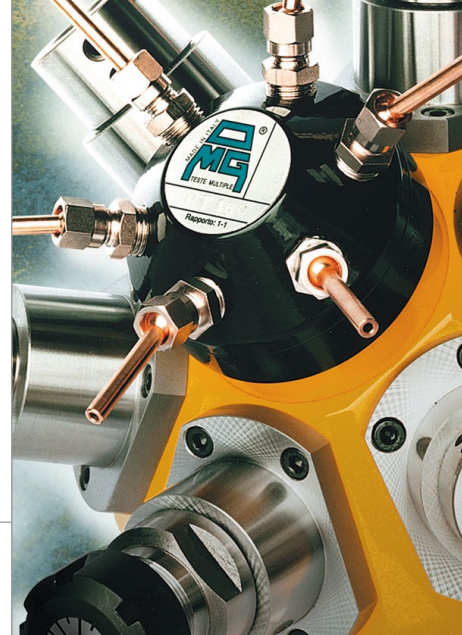

BAH
TA.CP
TA
MO
HT
VH
TSI/TSX
T
MT-TC-TC3
Accessori
Accessories
Appendice tecnica
Technical supplement

torrette a revolver turret heads

Le torrette a revolver serie **HT** sono una novità della produzione O.M.G. Nate dall'esigenza di aumentare la flessibilità delle macchine utensili, possono eseguire lavorazioni di foratura, filettatura, alesatura, fresatura. Trovano collocazione direttamente sul mandrino della macchina o, con motorizzazione propria, montate su slitte a uno o più assi di movimento. Disponibili in tre grandezze, hanno la possibilità di montare teste multiple, teste ad angolo e moltiplicatori di giri per aumentare la velocità dell'utensile. Tutte le versioni utilizzano un sistema di posizionamento tramite corona Hirth; questa soluzione costruttiva permette grande precisione, grande rigidità nelle lavorazioni di fresatura e alesatura di finitura, grande ripetitività.

- Costruzione torretta in acciaio e ghisa.
- Mandrini montati su cuscinetti di precisione.
- Mandrini con diverso attacco utensile (DIN55058, Komet, HSK, ecc) intercambiabili sulla stessa torretta.
- Mandrini in presa diretta con la presa di forza per sfruttare appieno la potenza
- Sistema idraulico di bloccaggio-sbloccaggio corona Hirth.
- La stessa motorizzazione permette la rotazione della torretta e la rotazione dei mandrini.
- Rotazione torretta bidirezionale per ricercare più velocemente il mandrino necessario alla lavorazione da eseguire.
- Refrigerante indipendente per ogni mandrino.
- Possibilità del refrigerante di passare attraverso il centro del mandrino.
- Lubrificazione effettuata a grasso o con miscela olio-aria.
- Pressurizzazione torretta
- Connettore unico per l'interscambio dati tra la torretta ed il cnc.

La serie **HT**, quindi, conferma la capacità di O.M.G. di affinare la gamma degli strumenti ad elevata affidabilità per le lavorazioni industriali e di puntare al centro delle esigenze della propria clientela offrendo sempre, come risorsa per l'innovazione, la versatilità dei propri prodotti.

*The **HT** series of turret heads are a novelty in the O.M.G. production range. Inspired by the need to increase the flexibility of machine tools, they are able to perform drilling, tapping, boring and milling. They can be installed directly on the machine spindle or, with their own drive, mounted on slides with one or more movement axes.*

Available in three sizes, they can be fitted with multispindle heads, angle heads and multipliers for greater tool velocity.

All versions use a positioning system based on a Hirth crown gear, providing utmost precision, excellent strength in milling and finishing boring and outstanding repeatability.

- Turret made of steel and cast iron
- Spindles mounted on precision bearings
- Spindles with different tool connections (HSK, Komet, DIN55058, etc.) which can be interchanged on the same turret
- Spindles directly engaged with p.t.o. to exploit power to the full
- Hydraulic Hirth crown gear locking-release system
- Single drive rotates both turret and spindles
- Two-way turret rotation for quicker retrieval of the spindle needed for the next process
- Separate coolant for each spindle
- Coolant through the spindle centre
- Lubrication with grease or oil-air mixture
- Pressurised turret
- Single connector for data exchange between turret and cnc.

*The **HT** series once more reflects O.M.G.'s ability to constantly perfect its range of highly reliable tools for industrial machining and to target the exact needs of its customers, offering product versatility as a resource for innovation.*

Caratteristiche tecniche/Features 5-2

Applicazioni/Applications 5-3



HT 160



F1 circuito olio per bloccaggio-sbloccaggio torretta
oil circuit for turret locking-release

F2 entrata refrigerante utensili
coolant tools

F3 fori fissaggio torretta
turret fixing holes

F4 entrata olio-aria
input oil-air

F5 connettore elettrico
electric connector

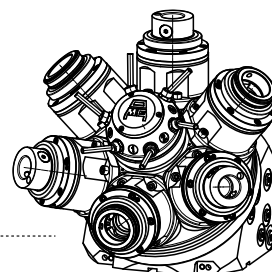

HT 200

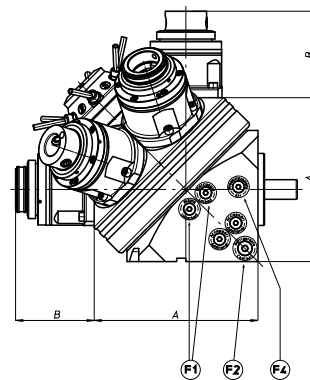
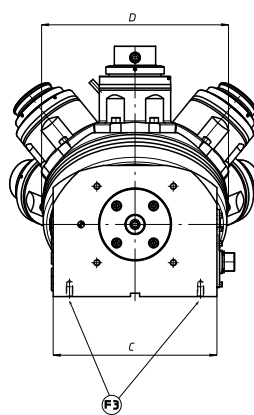
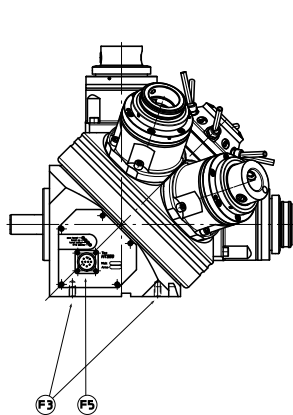

HT 250



HT 360



		HT 160	HT 200	HT 250	HT 360
n° di posizioni max max nr. of position		6	6	6-8	6-8-12
coppia trasmissibile al mandrino transmitting torque by spindle	Nm	80	200	300	800
n° giri max mandrino max rpm spindle		12.000	10.000	10.000	8.000
precisione di posizione mandrini precision of spindles positioning		± 3"	± 3"	± 3"	± 3"
potenza motore motor power	approx Kw	4	5	6,5	16
tempo di rotazione (1/6 di giro) indexing time 1/6 of rotation	sec	0,9	1	1,1	1,5
diametro corona Hirth dimension rings Hirth	mm	160	200	250	350
A		160	200	250	360
B dipende dal tipo di mandrino to depend on the spindle type	approx mm	70/80	100/150	100/150	120/170
C		160	200	250	350
D		180	228	290	400
tipi di mandrini disponibili type of spindles		ABS, HSK, ER, DIN 55058			
peso weight	kg	35	60	140	300

BAH

TA-CP

TA

MO

HT

VH

TSI/TSX

T

MT-TC-TC3

Accessori
Accessories

Appendice tecnica
Technical supplement



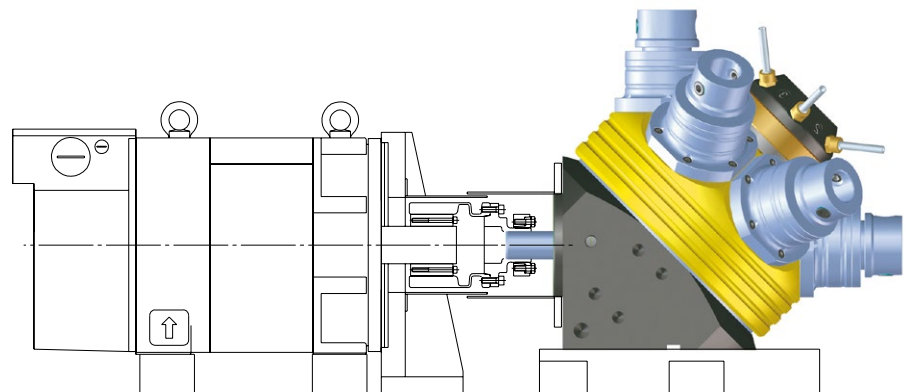
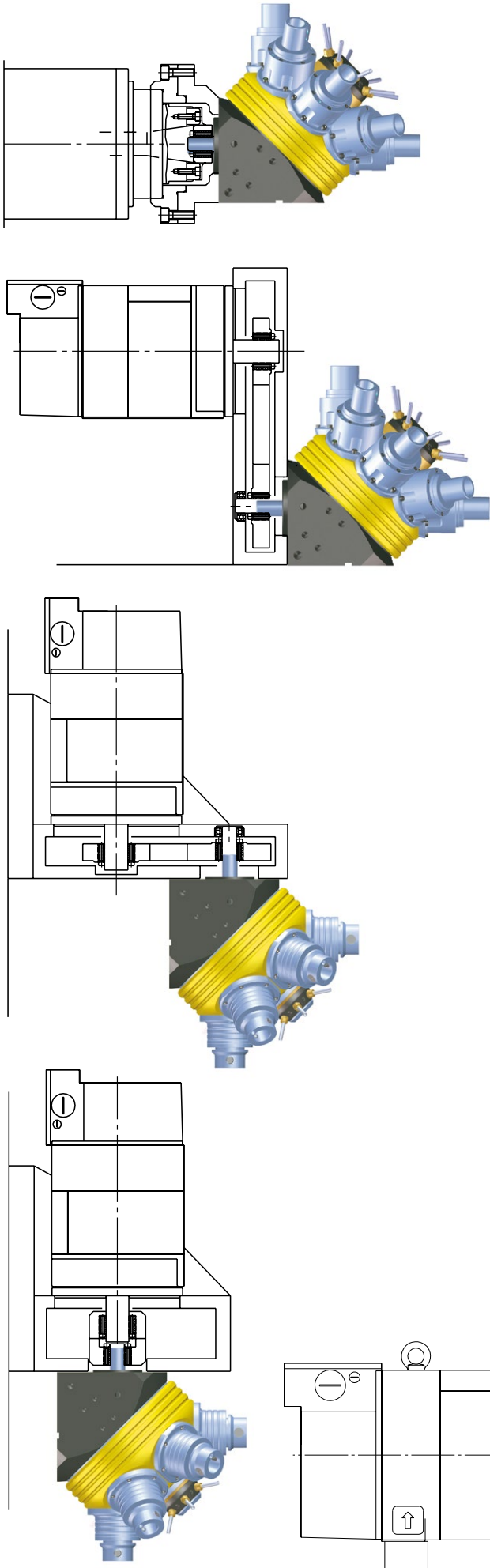

BAH

TA.CP

TA

MO

HT

VH

TSI/TSX

T

MT-TC-TC3

Accessori
Accessories

Appendice tecnica
Technical supplement



Gallery



HT 05007

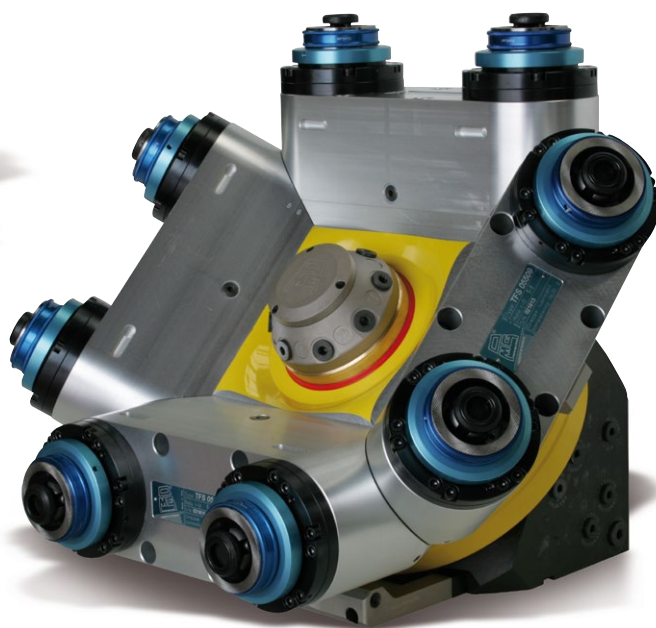

HT 05209



HT 31808



HT 08509

Gallery

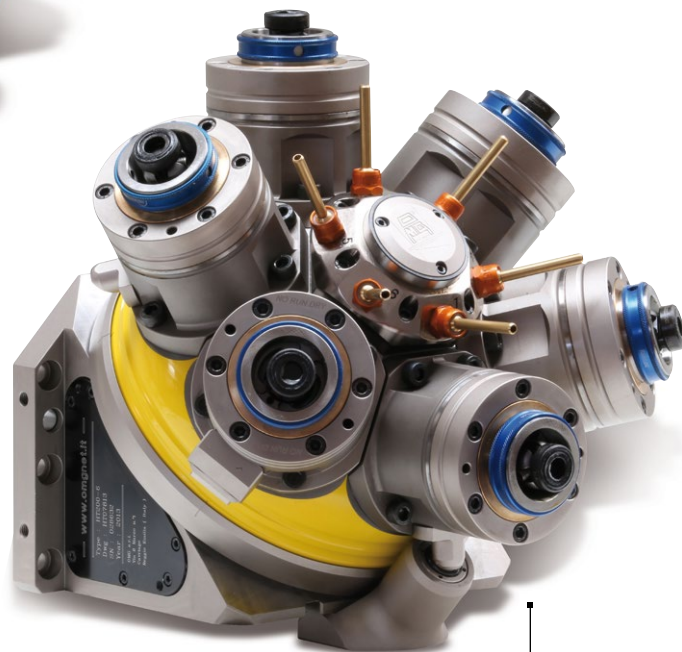
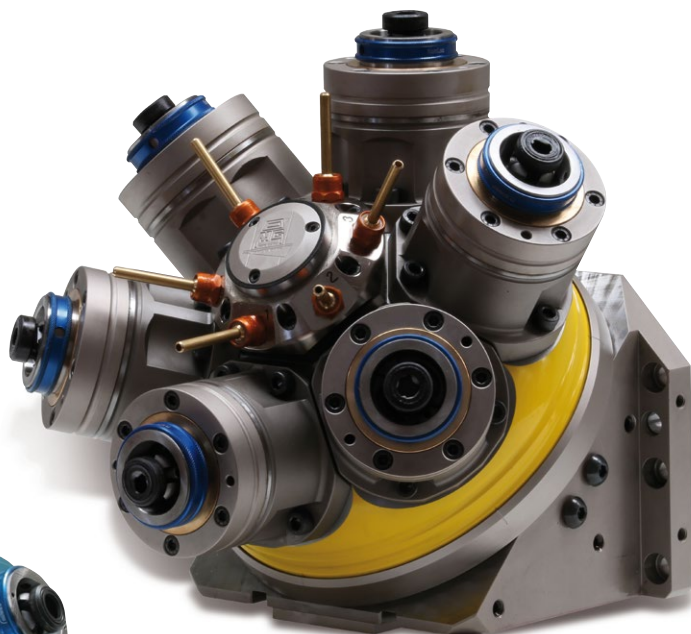

BAH

TA.CP

TA

MO

HT

VH

TSI/TSX

T

MT-TC-TC3

Accessori
Accessories

Appendice tecnica
Technical supplement

