

Multimar. Universal Measuring Instruments

Multimar 25 EWR Digital universal calipers	474
Overview	
Multimar 844 T and Accessoires	476
Multimar 844 T Universal Measuring Instrument	480
Multimar 844 Tw Depth stops for 844 Tma, 844 Tmi, 844 Te	482
Multimar 844 Tma Mounting attachments	483
Multimar 844 Tmi Mounting attachments	483
Multimar 844 Tms Mounting attachments with 90° offset	484
Multimar 844 Ta Shoulder Anvils	485
Multimar 844 Ti Shoulder Anvils	486
Multimar 844 Tz Cylindrical Measuring Pins	487
Multimar 844 Tv Interchangeable Measuring Rollers	488
Multimar 844 Te Measuring Arms	490
Multimar 844 Tp Anvils for Measuring Arms	491
Multimar 844 Ts Measuring Anvils	492
Multimar 844 Tk Ball Anvils	495
Multimar 844 Ty Holder for Measuring Rollers	497
Multimar 36 B Indicator Gages for Internal (i.D) and External (O.D.) Measurements	499

Digital universal calipers Multimar 25 EWR



Application:

For measuring:

- Outside and inside diameters
- Centering shoulders
- Narrow collars
- External and internal tapers
- Dovetails
- Grooves
- Distances between hole centers

Technical Data

Order no.		4119000	4119001	4119002	4119003
Product type		25 EWR			
Application range outside	mm	0 – 300	0 – 600	0 – 1000	0 – 1250
Resolution	mm/inch	0.01 / 0.0005			
Error limit	mm	0.03			0.04

Order no.	a
	mm
4119000	480
4119001	790
4119002	1200
4119003	1450

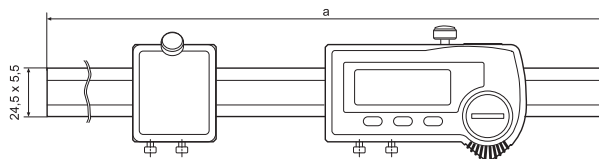

Accessories

Order no.	Product name	Quantity	Product type
		unit	
4102520	Battery 3 V, CR 2032		
4102915	Digimatic data cable (2 m)		16 EWd
4102410	Data Connection Cable RS232C (2 m)		16 EXr
4102357	Data Connection Cable USB (2 m)		16 EXu
4102231	Transmitter for e-Stick		16 EWe
4118520	Setting gage		25 Eel
4503030	Mounting attachments	Pair	844 Tma
4503031	Mounting attachments	Pair	844 Tmi
4503024	Measuring Arms, 25 mm	Pair	844 Te
4503025	Measuring Arms, 35 mm	Pair	844 Te
4503026	Measuring Arms, 70 mm	Pair	844 Te
4503027	Measuring Arms, 100 mm	Pair	844 Te
4503109	Depth stops for 844 Tma, 844 Tmi, 844 Te	Pair	844 Tw
4119010	Measuring tips for drill hole intervals, Ø 2–20 mm		25 Eba
4119011	Measuring tips for drill hole intervals, Ø 10–40 mm		25 Eba
4503020	Case for accessories		844 Tzb



16 EWe



844 Tma



844 Tw

Functions:

- ON/OFF
- AUTO-ON / OFF
- RESET (set display to zero)
- mm/inch
- PRESET (for entering a numerical value)
- LOCK function (key lock)
- DATA (Data transmission via connection cable)
- Interchangeable measuring arms, contact blocks and stop elements (optional accessories) for easy adaptation to individual measuring tasks
- The digital display is always in the operator's line of vision due to the patented mounting fixture of the measuring elements provided on the upper and lower longitudinal face of the arm holders
- Application range can be extended by turning the measuring arms
- The two arm holders can be moved along the rail, providing a well-balanced weight distribution, even with small dimensions
- Slide and rail are made of hardened stainless steel
- **Software:** MarCom Professional free download: www.mahr.com/marcom (only for Mahr data cables and wireless systems with USB and RS232 interface)
- **Data interface:** USB, Digimatic, Opto RS232C, Wireless
- **Energy supply:** Battery life approx. 3 years
- **IP protection category:** IP 65
- **Scope of delivery:** Battery, Instruction manual, Mounting and resting blocks, Wooden case, without arms/attachments and anvils

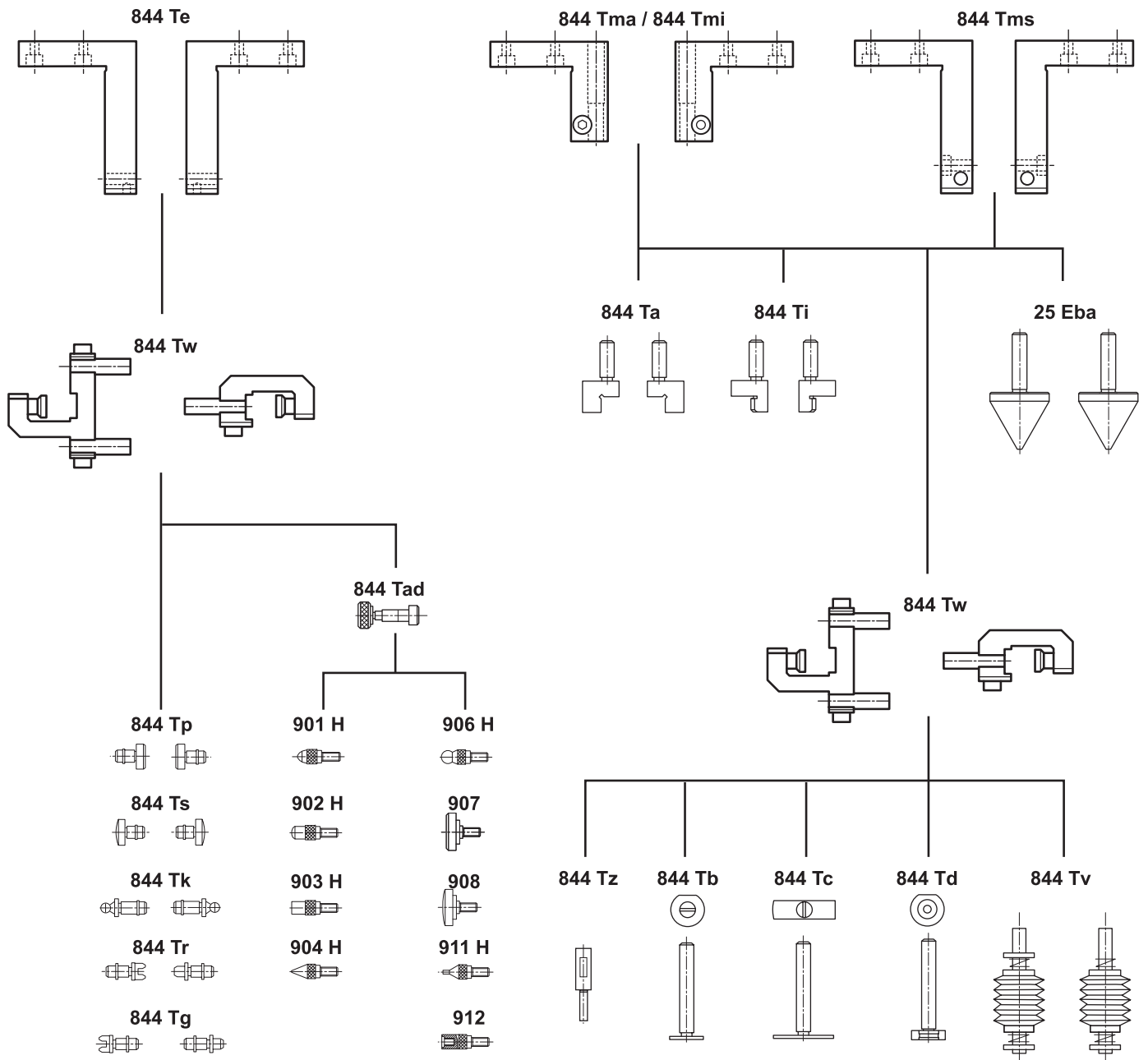

Multimar. Universal Gage 844 T for external and internal dimensions

OVERVIEW

The Universal Gage **Multimar** 844 T is easy to use and versatile; ideal for all your measuring requirements in dimensional metrology.

Applications

- For measuring:
 - External and internal dimensions
 - External and internal threads
 - Centering shoulders, narrow collars, recesses and grooves
 - External and internal tapers, external and internal tooth profiles/gears, etc.



All indicating instruments with an 8 mm mounting shank are applicable

Constant measuring force due to built-in measuring force spring

The movable measuring arm holder is mounted on a high precision ball guide to eliminate both play and friction; it also has extreme measuring sensitivity and accuracy due to optimal stability and ease of movement

Stop with non-tilting 3-point support for adjusting the measuring depth

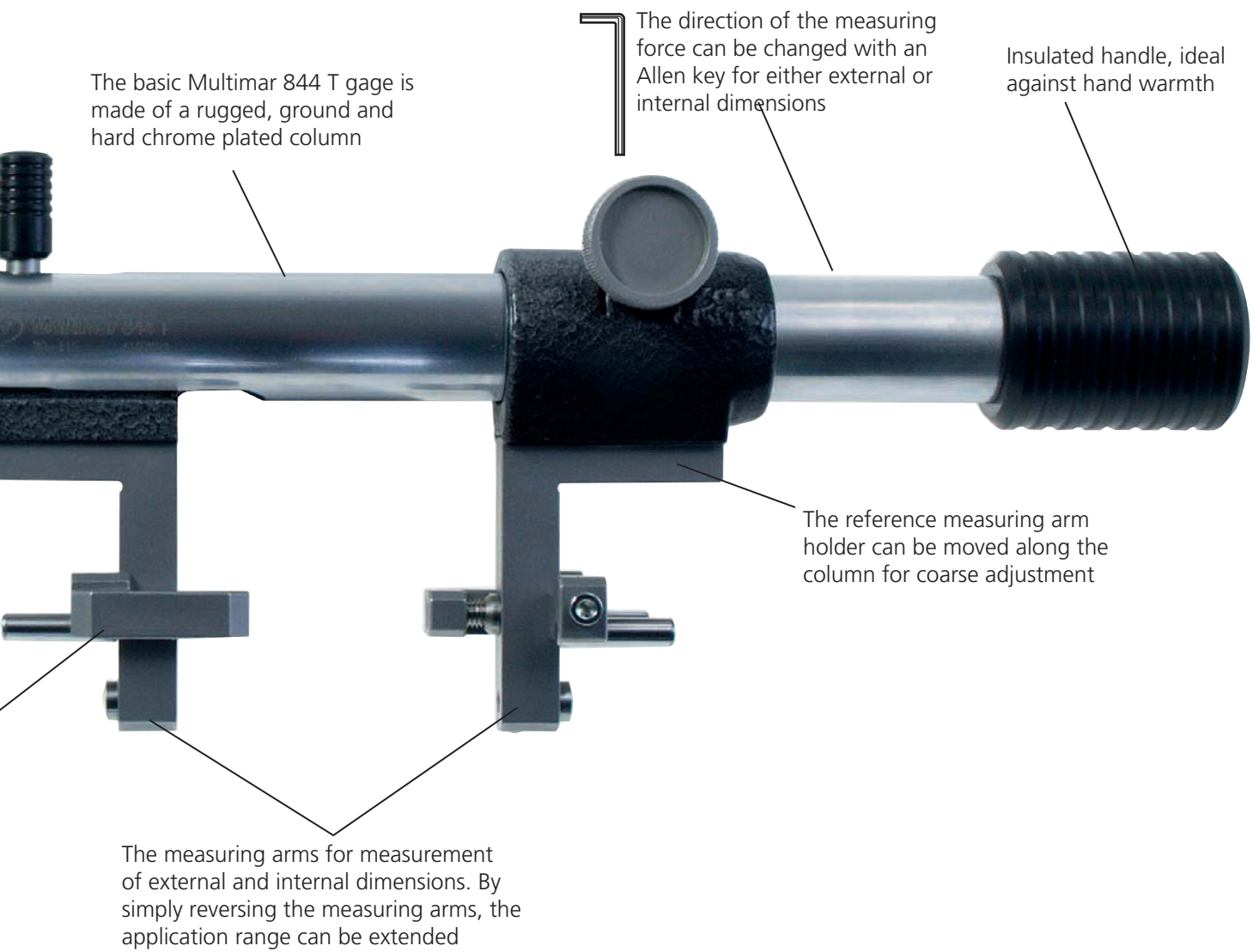

Universal Measuring Instrument Multimar 844 T

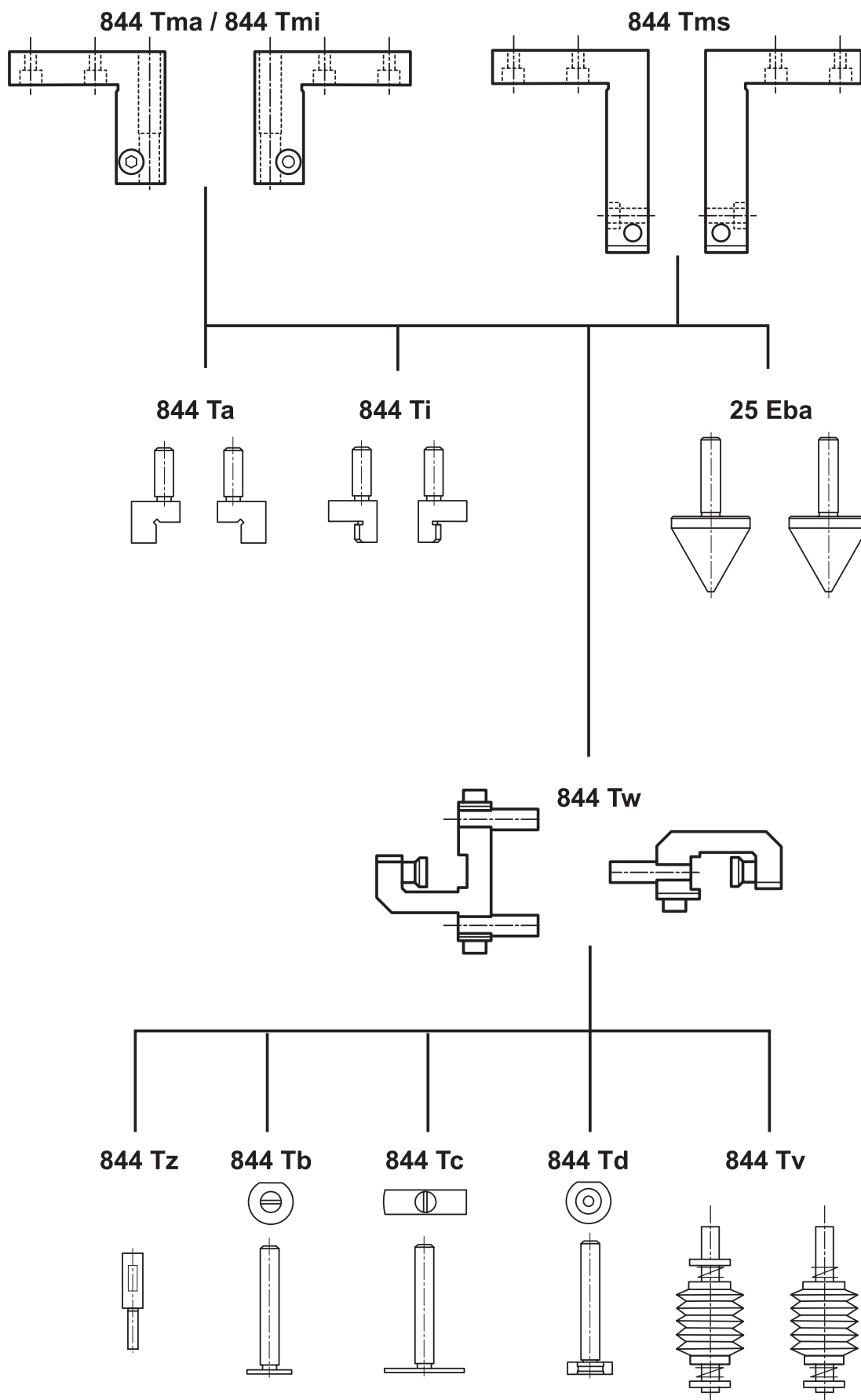

844 Te

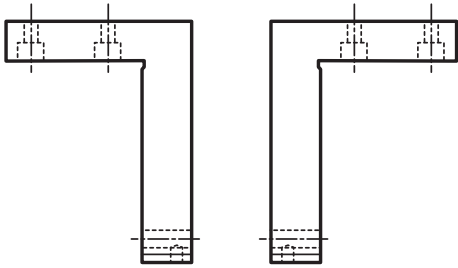

844 Ty

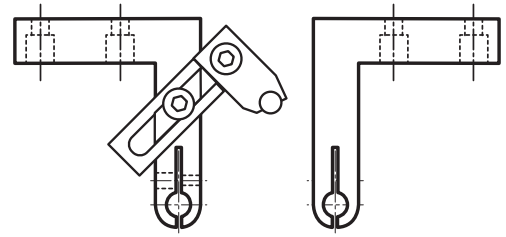

844 Tw

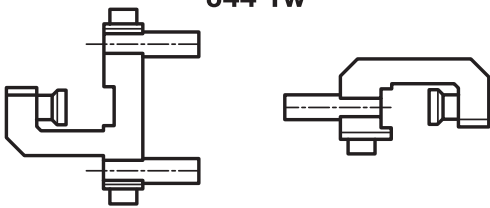

706 Vr

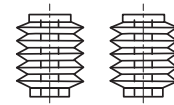

844 Tad

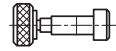

844 Tp



901 H



906 H



844 Ts



902 H



907



844 Tk

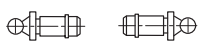

903 H



908



844 Tr



904 H



911 H



844 Tg

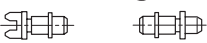

912



Universal Measuring Instrument Multimar 844 T

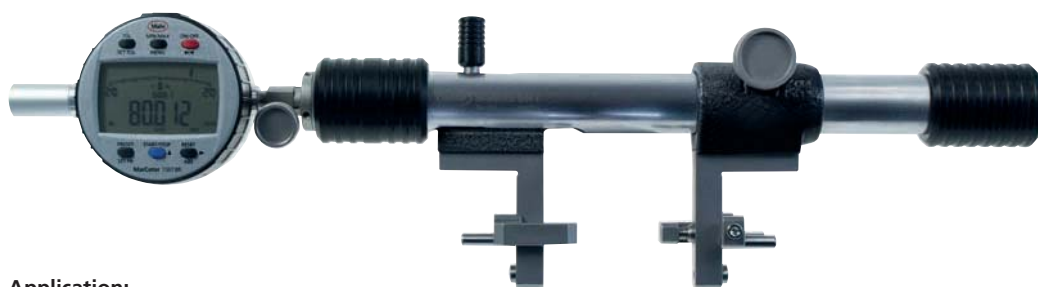

Application:

- External and internal dimensions
- External and internal threads
- Centering shoulders, narrow collars, recesses and grooves
- External and internal tapers, external and internal tooth profiles / gears, etc.



- Interchangeable measuring arms, contact blocks and stop elements (optional accessories) for easy adaptation to individual measuring tasks
- The movable measuring arm carrier is mounted on a high precision ball bearing guide for reduced play and friction
- Results in high measuring sensitivity, accuracy and free movement
- Stable support elements for repeatable measurements
- Constant measuring force with integrated measuring force spring
- Reversible measuring force direction for outside and inside measurement
- Highly stable, precision ground, hard chrome plated guide tube
- Lightweight construction with core made from carbon fiber reinforced plastic (CRP) tube, for measuring range 1000–1500 mm
- The stationary measuring arm holder can be moved along the guide tube and clamped for coarse adjustment
- **Scope of delivery:** Instruction manual, Mounting and resting blocks, Wooden case, excludes indicator, without arms/attachments and anvils

Technical Data

Order no.	4503001	4503002	4503003	4503004	4503005	4503006	4503007	
Product type	844 T							
Application range outside	mm	0 – 85	80 – 235	230 – 585	580 – 985	970 – 1470	1470 – 1970	1970 – 2470
Application range inside	mm	30 – 115	110 – 265	260 – 615	610 – 1015	1000 – 1500	1500 – 2000	2000 – 2500
Measuring force	N	5			10			
Probe path	mm	12						
Product weight	kg	0.78	1.01	1.59	2.22	2.52	2.68	2.86

Order no.	a
	mm
4503001	280
4503002	430
4503003	740
4503004	1140
4503005	1680
4503006	2180
4503007	2680

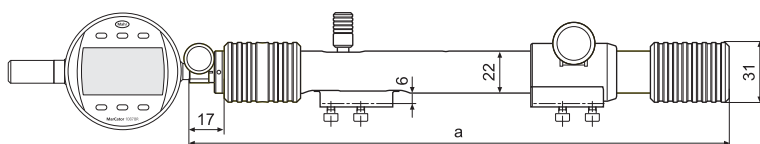

Universal Measuring Instrument Multimar 844 T

Accessories

Order no.	Product name	Quantity unit	Product type
4311000	Precision Dial Indicator, 0.01 mm, 10 mm		810 S
4333000	Millimes 5 μm , $\pm 130 \mu\text{m}$		1004
4332000	Millimes 0.01 mm, $\pm 0.25 \text{ mm}$		1010
4337662	Digital Indicator, 0.0005 mm, 12.5 mm		1087 BR
4337664	Digital Indicator, 0.0005 mm, 12.5 mm		1087 BRi
4503030	Mounting attachments	Pair	844 Tma
4503031	Mounting attachments	Pair	844 Tmi
4503024	Measuring Arms, 25 mm	Pair	844 Te
4503025	Measuring Arms, 35 mm	Pair	844 Te
4503026	Measuring Arms, 70 mm	Pair	844 Te
4503027	Measuring Arms, 100 mm	Pair	844 Te
4503040	Mounting attachments with 90° offset	Pair	844 Tms
4503041	Mounting attachments with 90° offset	Pair	844 Tms
4503109	Depth stops for 844 Tma, 844 Tmi, 844 Te	Pair	844 Tw
4503012	Protection for indicator		844 Tsb
4503020	Case for accessories		844 Tzb
4450512	Stand		844 Tf



810 S



1004



1087 BR



1087 BRi



844 Tma



844 Tw

Depth stops for 844 Tma, 844 Tmi, 844 Te Multimar 844 Tw

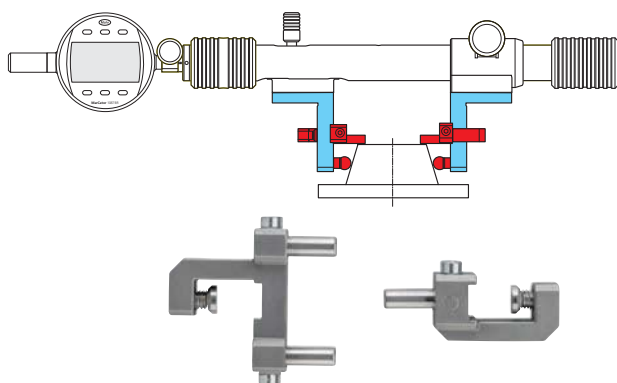

- Stops with stall protected 3-point support
- Hardened stop pins
- Interchangeable and adjustable

Application:

- For adjustment of the measuring depth in horizontal measuring position
- Precise stops in one plane for repeatable measurements
- To be mounted on 844 Tma, 844 Tmi, 844 Te
- For easy setting of the measuring depth, a mm scale is engraved on the measuring arms 844 Tma, 844 Tmi and 844 Te
- For precise setting of the measuring depth (i.e. for taper measurements) gage blocks can be used

Technical Data

Order no.	Quantity unit	Product type
4503109	Pair	844 Tw

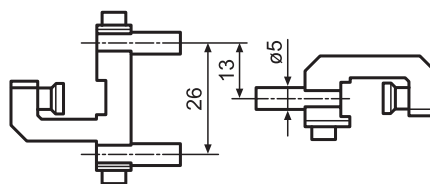

Mounting attachments Multimar 844 Tma / 844 Tmi

- For outside- (844 Tma) and inside diameters(844 Tmi)
- Stainless steel
- Lateral mm scale for easy positioning and adjustment of measuring limit stops
- Reversible measuring arms on measuring arm holders to increase the measuring range
- With $\varnothing 5$ mm mounting bore for inserting interchangeable 844 Ta, 844 Ti, 844 Tb, 844 Tc, 844 Td, 844 Tz and 844 Tv measuring anvils

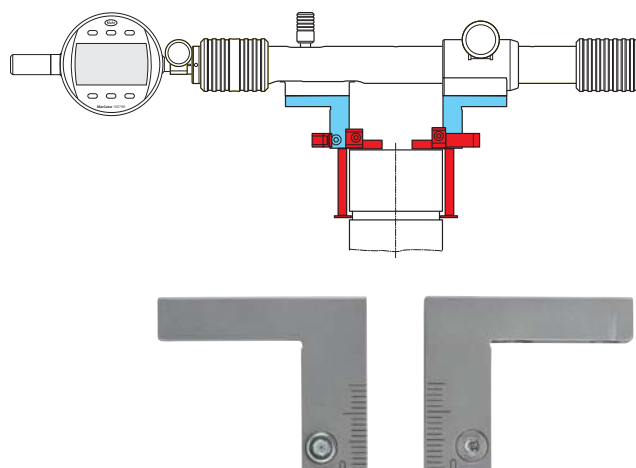

Technical Data

Order no.	Mounting hole	Quantity	unit	Product type
	mm			
4503030	5	Pair		844 Tma
4503031	5	Pair		844 Tmi

Order no.	a	b	Mounting hole
	mm	mm	mm
4503030	24	32	5
4503031	24	32	5

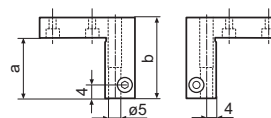

844 Tmi

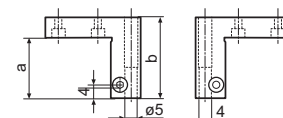

844 Tma

Accessories

Order no.	Product name	Quantity	unit	Product type
4500050	Shoulder Anvils, flat, hardened steel	Pair		844 Ta
4500055	Shoulder Anvils, spherical, hardened steel	Pair		844 Ti
4503015	Measuring anvils with measuring blades, Platelet diameter 11 mm, Adjustment range 0 –20 mm	Piece		844 Tb
4503016	Measuring anvils with measuring blades, Platelet diameter 11 mm, Adjustment range 20 –40 mm	Piece		844 Tb
4503017	Anvils with round measuring faces, Diameter 11 mm, Adjustment range 0 –20 mm	Piece		844 Td
4503018	Anvils with round measuring faces, Diameter 11 mm, Adjustment range 20 –40 mm	Piece		844 Td
4503109	Depth stops for 844 Tma, 844 Tmi, 844 Te	Pair		844 Tw
4503114	Measuring anvils with measuring blades, Platelet length 20 mm, Adjustment range 0 –20 mm	Piece		844 Tc
4503115	Measuring anvils with measuring blades, Platelet length 20 mm, Adjustment range 20 –40 mm	Piece		844 Tc



844 Tw

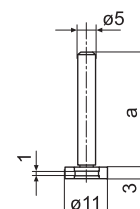

844 Td

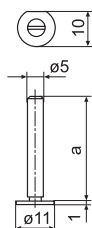

844 Tb

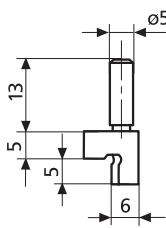

844 Ti

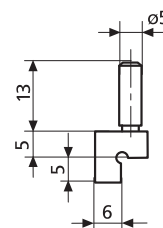

844 Ta

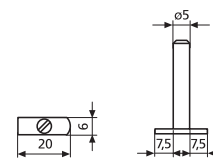

844 Tc

Mounting attachments with 90° offset Multimar 844 Tms



- For major and minor diameters
- Stainless steel
- Reversible measuring arms on measuring arm holders to increase the measuring range
- With $\varnothing 5$ mm holder for inserting interchangeable 844 Ta, 844 Ti, 844 Tb, 844 Tc, 844 Td, 844 Tz and 844 Tv measuring anvils

Application:

- Measure outer and inner dimensions with side probes
- in flat recesses
- in holes with center hub
- in holes with retracted drill rod

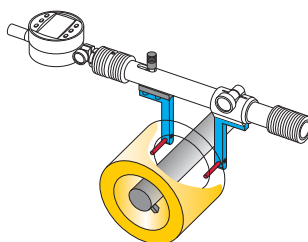

Technical Data

Order no.	Mounting hole	Throat depth	Quantity unit	Product type
	mm	mm		
4503040	5	50	Pair	844 Tms
4503041	5	100	Pair	844 Tms

Order no.	b	Mounting hole
	mm	mm
4503040	12	5
4503041	12	5

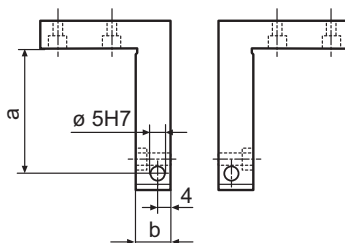

Accessories

Order no.	Product name	Quantity unit	Product type
4500050	Shoulder Anvils, flat, hardened steel	Pair	844 Ta
4500055	Shoulder Anvils, spherical, hardened steel	Pair	844 Ti
4503015	Measuring anvils with measuring blades, Platelet diameter 11 mm, Adjustment range 0 –20 mm	Piece	844 Tb
4503016	Measuring anvils with measuring blades, Platelet diameter 11 mm, Adjustment range 20 –40 mm	Piece	844 Tb
4503017	Anvils with round measuring faces, Diameter 11 mm, Adjustment range 0 –20 mm	Piece	844 Td
4503018	Anvils with round measuring faces, Diameter 11 mm, Adjustment range 20 –40 mm	Piece	844 Td
4503114	Measuring anvils with measuring blades, Platelet length 20 mm, Adjustment range 0 –20 mm	Piece	844 Tc
4503115	Measuring anvils with measuring blades, Platelet length 20 mm, Adjustment range 20 –40 mm	Piece	844 Tc
5113123	Measuring ball insert, $\varnothing = 6$ mm, Carbide	Piece	TR5C

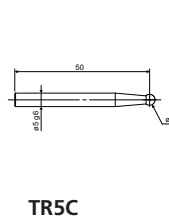
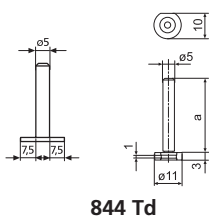
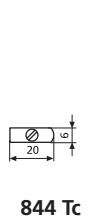
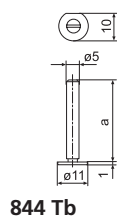
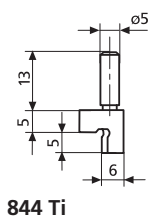
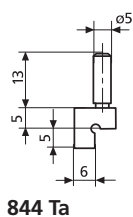

Shoulder Anvils Multimar 844 Ta

- With cylindrical mounting shaft to attach into the mounting attachments 844 Tma / 844 Tmi
- Flat; for external diameters
- Made of hardened steel

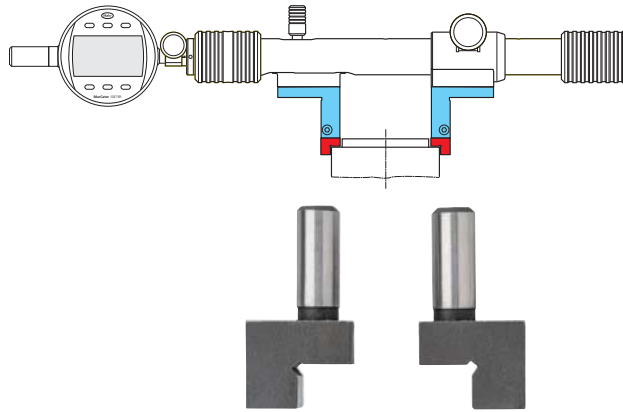

Application:

- For measuring narrow collars such as centering shoulders and other similar measuring tasks

Technical Data

Order no.	Mounting shaft diameter	Quantity unit	Product type
4500050	5 mm	Pair	844 Ta

Order no.	Mounting- \varnothing
4500050	5 mm

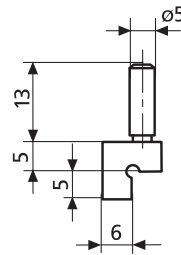

Shoulder Anvils Multimar 844 Ti

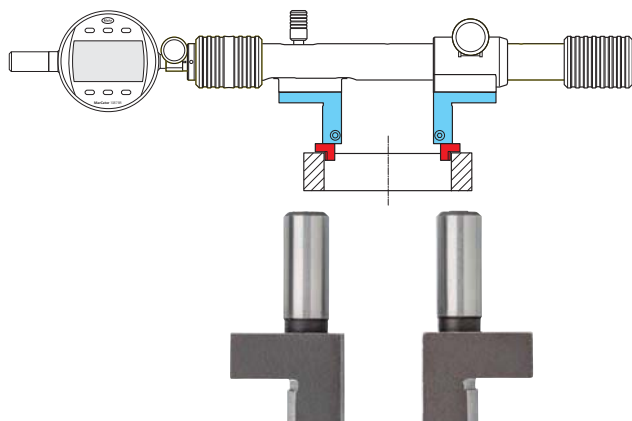

- With cylindrical mounting shaft to attach into the mounting attachments 844 Tma / 844 Tmi
- Semi-cylindrical, for internal diameters
- Made of hardened steel

Application:

- For measuring narrow collars such as centering shoulders and other similar measuring tasks

Technical Data

Order no.	Mounting shaft diameter	Quantity unit	Product type
	mm		
4500055	5	Pair	844 Ti

Order no.	Mounting- ϕ
	mm
4500055	5

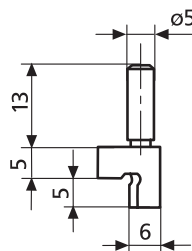

Cylindrical Measuring Pins Multimar 844 Tz

- With cylindrical holding shaft for fixing in 844 Tma / 844 Tmi mounting attachments
- Made of hardened steel

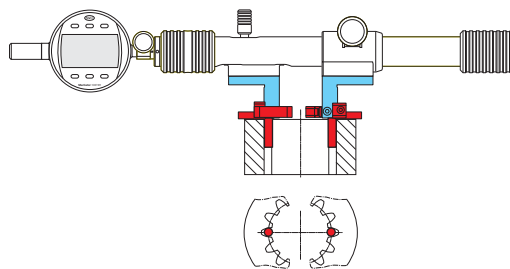

Application:

Determination of the dimension over 2 pins for inner and outer gears

Technical Data

Order no.	D	Mounting shaft diameter	Manufacturing tolerance +/-	Quantity unit	Product type
	mm	mm	μm		
4500500	1	5	2	Pair	844 Tz
4500501	1.25	5	2	Pair	844 Tz
4500502	1.5	5	2	Pair	844 Tz
4500503	1.75	5	2	Pair	844 Tz
4500504	2	5	2	Pair	844 Tz
4500506	2.5	5	2	Pair	844 Tz
4500507	3	5	2	Pair	844 Tz
4500508	3.5	5	2	Pair	844 Tz
4500509	4	5	2	Pair	844 Tz
4500510	4.5	5	2	Pair	844 Tz
4500511	5	5	2	Pair	844 Tz
4500512	5.5	5	2	Pair	844 Tz
4500513	6	5	2	Pair	844 Tz

Order no.	D	Dimension L	l	Mounting- ϕ
	mm	mm	mm	mm
4500500	1	19.5	6	5
4500501	1.25	19.5	6	5
4500502	1.5	19.5	6	5
4500503	1.75	23.5	10	5
4500504	2	23.5	10	5
4500506	2.5	23.5	10	5
4500507	3	28.5	15	5
4500508	3.5	28.5	15	5
4500509	4	28.5	15	5
4500510	4.5	33.5	20	5
4500511	5	33.5	20	5
4500512	5.5	33.5	20	5
4500513	6	33.5	20	5

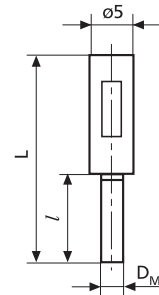

Multimar 844 Tv. Interchangeable measuring rollers

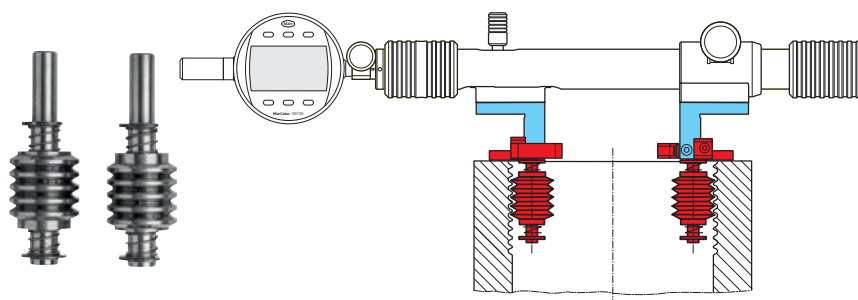

- With cylindrical holding shaft for fixing in 844 Tma / 844 Tmi mounting attachments
- Made of hardened steel
- Each with two springs to aid insertion in correct thread turn
- Contact rollers for other thread pitches (metric 60°) as well as for Whitworth and UST thread on request

Application:

Determining the pitch diameter of outer and inner threads

Technical Data

Order no.	Flank angle	Type of thread	Thread parameter	Thread pitch in TPI	Thread pitch in mm	d	Quantity unit	Product type
				TPI	mm	mm		
4501705	60°	Metric thread	Pitch diameter		0,5	5	Pair	844 Tv
4501706	60°	Metric thread	Pitch diameter		0,6	5	Pair	844 Tv
4501707	60°	Metric thread	Pitch diameter		0,7	5	Pair	844 Tv
4501708	60°	Metric thread	Pitch diameter		0,75	5	Pair	844 Tv
4501709	60°	Metric thread	Pitch diameter		0,8	5	Pair	844 Tv
4501710	60°	Metric thread	Pitch diameter		0,9	5	Pair	844 Tv
4501711	60°	Metric thread	Pitch diameter		1	5	Pair	844 Tv
4501712	60°	Metric thread	Pitch diameter		1,25	5	Pair	844 Tv
4501713	60°	Metric thread	Pitch diameter		1,5	5	Pair	844 Tv
4501714	60°	Metric thread	Pitch diameter		1,75	5	Pair	844 Tv
4501715	60°	Metric thread	Pitch diameter		2	5	Pair	844 Tv
4501716	60°	Metric thread	Pitch diameter		2,5	5	Pair	844 Tv
4501717	60°	Metric thread	Pitch diameter		3	5	Pair	844 Tv
4501718	60°	Metric thread	Pitch diameter		3,5	5	Pair	844 Tv
4501719	60°	Metric thread	Pitch diameter		4	5	Pair	844 Tv
4501720	60°	Metric thread	Pitch diameter		4,5	5	Pair	844 Tv
4501721	60°	Metric thread	Pitch diameter		5	5	Pair	844 Tv
4501722	60°	Metric thread	Pitch diameter		5,5	5	Pair	844 Tv
4501723	60°	Metric thread	Pitch diameter		6	5	Pair	844 Tv
4501750	55°	Whitworth thread	Pitch diameter	6		5	Pair	844 Tv
4501751	55°	Whitworth thread	Pitch diameter	7		5	Pair	844 Tv
4501752	55°	Whitworth thread	Pitch diameter	8		5	Pair	844 Tv
4501753	55°	Whitworth thread	Pitch diameter	9		5	Pair	844 Tv
4501754	55°	Whitworth thread	Pitch diameter	10		5	Pair	844 Tv
4501755	55°	Whitworth thread	Pitch diameter	11		5	Pair	844 Tv
4501756	55°	Whitworth thread	Pitch diameter	12		5	Pair	844 Tv
4501757	55°	Whitworth thread	Pitch diameter	13		5	Pair	844 Tv
4501758	55°	Whitworth thread	Pitch diameter	14		5	Pair	844 Tv
4501759	55°	Whitworth thread	Pitch diameter	16		5	Pair	844 Tv
4501760	55°	Whitworth thread	Pitch diameter	18		5	Pair	844 Tv
4501761	55°	Whitworth thread	Pitch diameter	19		5	Pair	844 Tv
4501762	55°	Whitworth thread	Pitch diameter	20		5	Pair	844 Tv
4501763	55°	Whitworth thread	Pitch diameter	22		5	Pair	844 Tv

- 0+

Multimar 844 Tv. Interchangeable measuring rollers

Technical Data

Order no.	Flank angle	Type of thread	Thread parameter	Thread pitch	Thread pitch	d	Quantity unit	Product type
				in TPI	in mm			
4501764	55°	Whitworth thread	Pitch diameter	24		5	Pair	844 Tv
4501765	55°	Whitworth thread	Pitch diameter	28		5	Pair	844 Tv
4501766	55°	Whitworth thread	Pitch diameter	30		5	Pair	844 Tv
4501767	55°	Whitworth thread	Pitch diameter	32		5	Pair	844 Tv
4501768	55°	Whitworth thread	Pitch diameter	36		5	Pair	844 Tv
4501769	55°	Whitworth thread	Pitch diameter	40		5	Pair	844 Tv
4501800	60°	UST Thread	Pitch diameter	6		5	Pair	844 Tv
4501801	60°	UST Thread	Pitch diameter	7		5	Pair	844 Tv
4501802	60°	UST Thread	Pitch diameter	8		5	Pair	844 Tv
4501803	60°	UST Thread	Pitch diameter	9		5	Pair	844 Tv
4501804	60°	UST Thread	Pitch diameter	10		5	Pair	844 Tv
4501805	60°	UST Thread	Pitch diameter	11		5	Pair	844 Tv
4501806	60°	UST Thread	Pitch diameter	12		5	Pair	844 Tv
4501807	60°	UST Thread	Pitch diameter	13		5	Pair	844 Tv
4501808	60°	UST Thread	Pitch diameter	14		5	Pair	844 Tv
4501809	60°	UST Thread	Pitch diameter	16		5	Pair	844 Tv
4501810	60°	UST Thread	Pitch diameter	18		5	Pair	844 Tv
4501811	60°	UST Thread	Pitch diameter	19		5	Pair	844 Tv
4501812	60°	UST Thread	Pitch diameter	20		5	Pair	844 Tv
4501813	60°	UST Thread	Pitch diameter	22		5	Pair	844 Tv
4501814	60°	UST Thread	Pitch diameter	24		5	Pair	844 Tv
4501815	60°	UST Thread	Pitch diameter	28		5	Pair	844 Tv
4501816	60°	UST Thread	Pitch diameter	30		5	Pair	844 Tv
4501817	60°	UST Thread	Pitch diameter	32		5	Pair	844 Tv
4501818	60°	UST Thread	Pitch diameter	36		5	Pair	844 Tv
4501819	60°	UST Thread	Pitch diameter	40		5	Pair	844 Tv

Measuring Arms Multimar 844 Te

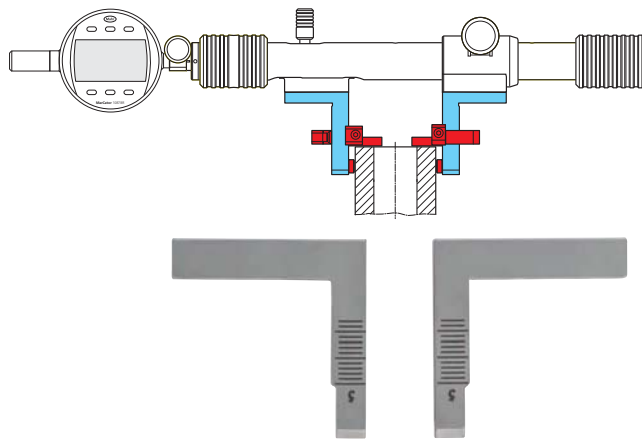

- For major and minor diameters
- Stainless steel
- Lateral mm scale for easy positioning and adjustment of measuring limit stops
- Reversible measuring arms on measuring arm holders to increase the measuring range
- 3.5 mm diameter holder for inserting interchangeable measuring anvils 844 Tp, 844 Ts, 844 Tk, 844 Tr and 844 Tg

Technical Data

Order no.	Mounting hole	Throat depth	Quantity unit	Product type
	mm	mm		
4503024	3.5	25	Pair	844 Te
4503025	3.5	35	Pair	844 Te
4503026	3.5	70	Pair	844 Te
4503027	3.5	100	Pair	844 Te

Order no.	a	Mounting hole
	mm	mm
4503024	6	3.5
4503025	10	3.5
4503026	10	3.5
4503027	12	3.5

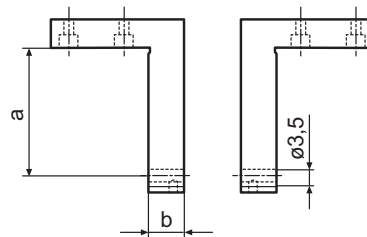

Accessories

Order no.	Product name	Quantity unit	Product type
4500040	Anvils for Measuring Arms, flat, hardened steel	Piece	844 Tp
4500045	Measuring Anvils, spherical, hardened steel	Piece	844 Ts
4503080	Adapter Ø 3,5 - M2,5 for measuring arms 844 Te	Piece	844 Tad
4503109	Depth stops for 844 Tma, 844 Tmi, 844 Te	Pair	844 Tw

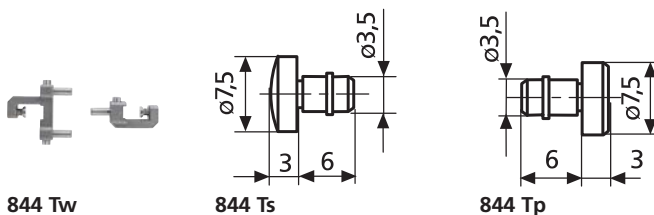

Anvils for Measuring Arms Multimar 844 Tp

- Hardened steel
- With cylindrical mounting shank and retainer ring which allows free rotation inside the bore of Measuring Arms 844 Te.

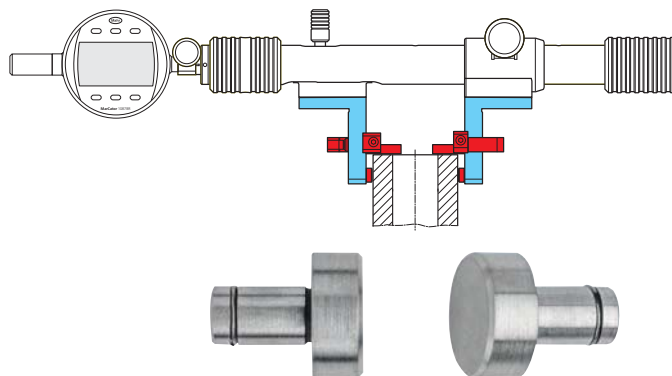

Application:

- Flat; for external diameters, distance and widths

Technical Data

Order no.	Mounting shaft diameter	Quantity unit	Product type
	mm		
4500040	3.5	Piece	844 Tp

Measuring Anvils Multimar 844 Ts

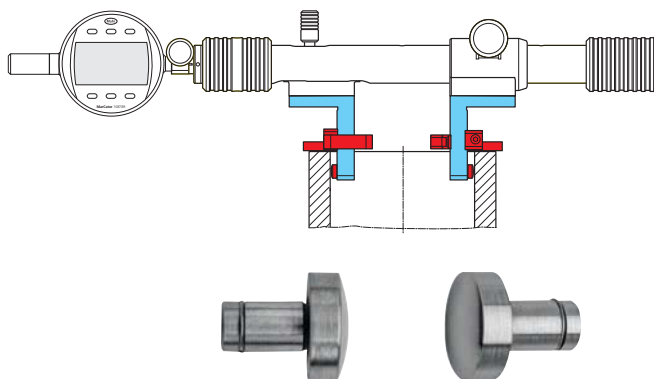

- Hardened steel
- With cylindrical mounting shank and retainer ring which allows free rotation inside the bore of Measuring Arms 844 Te.

Application:

- Spherical; for internal diameters

Technical Data

Order no.	Mounting shaft diameter	Quantity unit	Product type
4500045	mm 3.5	Piece	844 Ts

Multimar Thread anvils

- For pitch diameters
- With cylindrical mounting shank and retainer ring which ensures locking while permitting rotation in bore
- Hardened, wear-resistant special steel



Accessories

Thread pitch in mm	Taper Order no.	V-anvil Order no.	Blade Order no.
Pitch diameter, external thread			
Trapezoid 30°			
1		4501150	4501350
1,5		4501151	4501351
2		4501152	4501352
3		4501153	4501353
4		4501154	4501354
5		4501155	4501355
6		4501156	4501356
7		4501157	4501357
8		4501158	4501358
9		4501159	4501359
10		4501160	4501360
12		4501161	4501361
14		4501162	4501362
16		4501163	4501363
18		4501164	4501364
20		4501165	4501365
metric 60°			
0,5 – 0,7		4501000	4501200
0,7 – 1		4501001	4501201
1,25 – 2		4501002	4501202
2 – 3,5		4501003	4501203
3,5 – 5		4501004	4501204
5 – 7		4501005	4501205
7 – 9		4501006	4501206
Pitch diameter, internal thread			
Trapezoid 30°			
1	4501831	4501830	
1,5	4501833	4501832	
2	4501835	4501834	
3	4501837	4501836	
4	4501839	4501838	
5	4501841	4501840	
6	4501843	4501842	
7	4501845	4501844	
8	4501847	4501846	
9	4501849	4501848	
10	4501851	4501830	
12	4174981	4174961	
14	4174982	4174962	
16	4174983	4174963	
18	4174984	4174964	
20	4174985	4174965	

Multimar Thread anvils

Accessories

Thread pitch in mm	Taper Order no.	V-anvil Order no.	Blade Order no.
metric 60°			
0,5 –0,7	4174600	4174300	
0,7 –1	4174601	4174301	
1,25 –2	4174602	4174302	
2 –3,5	4174603	4174303	
3,5 –5	4174604	4174304	
5 –7	4174605	4174305	
7 –9	4174606	4174306	

- For pitch diameters
- With cylindrical mounting shank and retainer ring which ensures locking while permitting rotation in bore
- Hardened, wear-resistant special steel

Thread pitch in TPI	Taper Order no.	V-anvil Order no.	Blade Order no.
Pitch diameter, external thread			
UST 60°			
40 –32		4501018	4501418
32 –24		4501019	4501419
24 –18		4501020	4501420
18 –14		4501021	4501421
14 –10		4501022	4501422
10 –7		4501023	4501423
7 –4,5		4501024	4501424
4,5 –3		4501025	4501425
Whitworth 55 °			
40 –32		4501007	4501207
32 –24		4501008	4501208
24 –18		4501009	4501209
18 –14		4501010	4501210
14 –10		4501011	4501211
10 –7		4501012	4501212
7 –4,5		4501013	4501213
4,5 –3		4501014	4501214
Pitch diameter, internal thread			
UST 60°			
40 –32	4174615	4174415	
32 –24	4174616	4174416	
24 –18	4174617	4174417	
18 –14	4174618	4174418	
14 –10	4174919	4174419	
10 –7	4174620	4174420	
7 –4,5	4174621	4174421	
4,5 –3	4174622	4174422	
Whitworth 55 °			
40 –32	4174643	4174343	
32 –24	4174644	4174344	
24 –18	4174645	4174345	
18 –14	4174646	4174346	
14 –10	4174647	4174347	
10 –7	4174648	4174348	
7 –4,5	4174649	4174349	
4,5 –3	4174650	4174350	

Ball Anvils Multimar

- Measuring ball made of carbide. With cylindrical mounting shank and retainer ring which allows free rotation inside the bore of Measuring Arms 844 Te.

- manufacturing tolerance ball $\pm 2 \mu\text{m}$



Order no.	Dimension H	d
	mm	mm
4502620	3	0.5
4502621	3.1	0.551
4502622	3.1	0.62
4502623	3.1	0.623
4502624	3.1	0.63
4502625	3.2	0.722
4502626	3.4	0.862
4502627	3.4	0.895
4502628	3.5	0.965
4500350	3.5	1
4502629	3.6	1.1
4502630	3.6	1.118
4502631	3.6	1.125
4500351	3.8	1.25
4502632	3.9	1.35
4502633	3.9	1.372
4502634	3.9	1.385
4500352	4	1.5
4502635	4	1.524
4502636	4	1.54
4502637	4.1	1.6
4502638	4.2	1.65
4502639	4.2	1.7
4500353	4.3	1.75
4502640	4.3	1.782
4502641	4.3	1.8
4502642	4.3	1.829
4502643	4.4	1.9
4500354	4.5	2
4502543	4.5	2.032
4502540	4.8	2.25
4502644	4.8	2.284
4502544	4.8	2.3
4502645	4.9	2.386
4502646	4.9	2.438
4500356	5	2.5
4502647	5.2	2.667
4502648	5.2	2.704
4502649	5.2	2.713
4502650	5.2	2.721
4502651	5.2	2.743
4500618	5.3	2.75
4500357	5.5	3

Order no.	Dimension H	d
	mm	mm
4502652	5.5	3.048
4502541	5.8	3.25
4502653	5.9	3.4
4500358	6	3.5
4502654	6.2	3.658
4500359	6.5	4
4500360	7	4.5
4502655	7.3	4.835
4500361	7.5	5
4502656	7.8	5.25
4502657	8	5.486
4500362	8	5.5
4500363	8.5	6
4502658	8.6	6.096
4502545	8.9	6.35
4502542	9	6.5
4502547	9.5	7
4502548	10.5	8
4502549	11.5	9
4502550	12.5	10

Multimar 844 S. Setting device

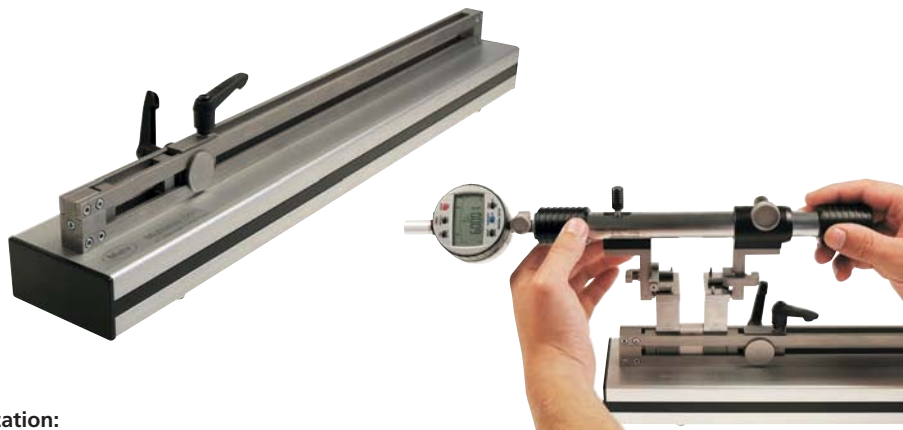

- Simple handling via clamping element
- Accurate setting of nominal value using gage block combinations
- Instrument setting in horizontal or vertical position (using base 844 Sf)
- Rigid base made of anodized aluminum, for mobile or stationary use in the production or in the inspection room
- **Scope of delivery:** Basic unit 844 S, Instruction manual

Application:

For setting indicating instruments for internal and external dimensions i. e. Multimar 844 T and Marameter 844 N at any dimension by using gage block combinations.

Technical Data

Order no.		4503500	4503501	4503502
Application range internal measurement up to	mm	400	1150	2180
Product type			844 S	

Order no.	device dimensions (LxBxH)
4503500	520 x 80 x 40 mm
4503501	1270 x 80 x 40 mm
4503502	2300 x 80 x 80 mm

Accessories

Order no.	Product description	Product type
4503510	T-shaped gage blocks (20mm) for measuring depth up to 40 mm	844 Sp
4503511	Riser blocks 30mm for extended measuring depths	844 Sph
4474080	Adjustment bridge (70 x 12 mm), for measuring range 18 –250 mm	844 Neb
4474081	Adjustment bridge (165 x 17 mm), for measuring range 18 –400 mm	844 Neb
4470095	Measuring jaw for holder 420 h	844 em
4503512	Fuß für Vertikaleinsatz, inkl. Schrauben und 2 Tischklemmen	844 Sf
4474082	Adjustment bridge (320 x 20 mm), for measuring range 18 –800 mm	844 Neb



Holder for Measuring Rollers Multimar 844 Ty

- With location bolts for the Measuring Rollers 706 Vr, plus a stop and stop pin



Application:

Determining the pitch diameter of outer threads

Technical Data

Order no.	Quantity unit	Product type
4502463	Pair	844 Ty

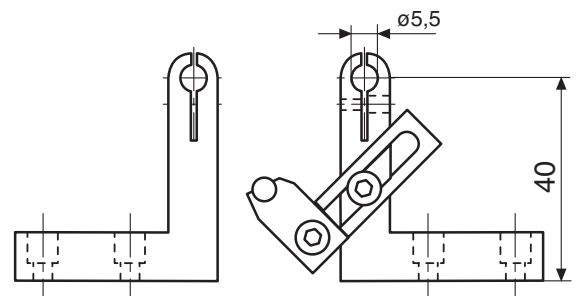

Indicator Gage Multimar EDI-36B / EMD-36B



- Excellent accuracy due to the parallel springs in the probe being frictionless and free of play.
- User friendly: the surface can be inclined between 0° and 90° with respect to the base.
- Adjustable measuring force
- **Data interface:** Digimatic, RS232C, USB
- **Energy supply:** Battery operation
- **Scope of delivery:** Set of jaws JW-9, Instruction manual



Application:

- For measuring internal and external diameters, centering edges, narrow shoulders and recesses.

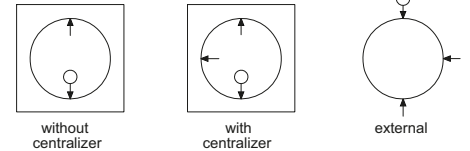

Technical Data

Order no.	2051693	2051695	2051863	2051873	2051864	2051874
Product type	EDI-36B-10	EDI-36B-20	EMD-36B-10	EMD-36B-20	EMD-36B-10D	EMD-36B-20D
Application range outside	mm 6 – 127	6 – 222	6 – 127	6 – 222	6 – 127	6 – 222
Application range outside	inch .25 – 5"	.25 – 8.75"	.25 – 5"	.25 – 8.75"	.25 – 5"	.25 – 8.75"
Application range inside	mm 19 – 89	19 – 197	19 – 89	19 – 197	19 – 89	19 – 197
Application range inside	inch .75 – 3.5"	.75 – 7.75"	.75 – 3.5"	.75 – 7.75"	.75 – 3.5"	.75 – 7.75"
Resolution	mm 0.0002, 0.0005, 0.001, 0.002, 0.005, 0.01, 0.02				0.0005, 0.001, 0.005	
Resolution	inch	.00002", .00005", .0001", .0005"				
Measuring force, adjustable	N	0 – 35				
Probe path, adjustable	mm	6 – 10 mm				
Probe path, adjustable	inch	.25 – .40"				
Indicating instrument (included in delivery)		2034201 µMaxµm II	2033109 Maxµm III	2033111 Maxµm III		

Order no.	Mounting bore
	inch
2051693	.375"
2051695	.375"
2051863	.375"
2051873	.375"
2051864	.375"
2051874	.375"

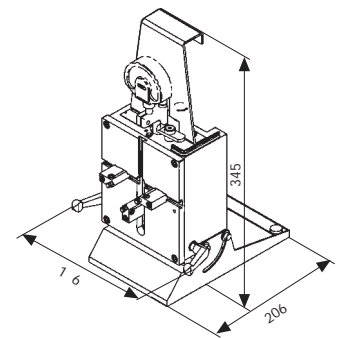

Accessories

Order no.	Product name	Product type
2003210	Jaw set, Material steel	JW-9
2003211	Jaw Set used with 36B Gage, Made of carbide	JW-58
2003215	Contact for JW-69, Material steel	PS-55
2003216	Contact for JW-58, Made of carbide	PS-226

