

Starrett®

Precision, Quality, Innovation

VB300 VB400

Vision Measurement Systems

Optical Comparators

Software



VERTICAL BENCH-TOP OPTICAL COMPARATORS

VB300

The VB300 is another optical comparator with the Starrett trademark formula: high performance at a low cost. This vertical bench top comparator is designed to meet the demands of modern industry and is ideal for the rapid inspection of small light-weight components, stampings, plastic molding, electronic components, small turned parts and more. The VB300 features a variety of digital displays making the VB300 easy to use and has the power to satisfy the most complex of measuring requirements.

FEATURES AND SPECIFICATIONS

- All metal construction for optimum performance
- 12" (300mm) diameter screen with overlay clips
- Linear encoder (glass scale) with 4µin (0.1µm) resolution on both X and Y axes
- Stage weight capacity: 11lbs (5kg) (evenly distributed)
- LED profile and surface illumination
- Screen driven Q-axis
- Quick release mechanism on X-axis and Y-axis
- Available with a simple integrated LED readout display or choice of the new MetLogix™ M1 tablet, M2 PC-based measuring software, or Mx-Series digital readout systems

OPTIONS

- Choice of four fixed magnification lenses including 10x, 20x, 25x and 50x
- Canopy and curtains- free standing design (see Pg. 51)
- Purpose built cabinet stand
- Work holding accessories

VB400

The VB400 Vertical Optical Comparator allows flat parts to be simply laid on a glass insert in the workstage. Features include a 16" (400mm) diameter vertical screen, ultra-bright LED profile and surface illumination, and linear encoder scales for 4µin (0.1µm) resolution.

FEATURES AND SPECIFICATIONS

- All metal construction
- 16" (400mm) diameter screen
- Collimating condenser with yellow/green filter and provision to mount further accessories
- Linear encoder (glass scale) with 4µin (0.1µm) resolution on both X and Y axes
- LED profile and surface illumination
- Digital protractor for accurate angle measurements (1' resolution) via Q-axis readout
- Available with MetLogix™ M1 tablet, M2 PC-based touch screen measuring software or Mx-Series digital readout system
- Fine adjustment on all axes
- Quick release mechanism on the X-Y axes

OPTIONS

- Choice of five fixed magnification lenses including 10x, 20x, 25x, 31.25x and 50x
- Canopy and curtains- free standing design (see Pg. 51)
- Purpose built cabinet stand
- Work holding accessories



Click the QR code to view the VB Series

OPERATOR INTERFACE- VB300

Feature	Integral LED readout	MetLogix™ M1	M2	Mx100	Mx200
Angular digital measurement in readout	x	—	—	—	x
Mounted to comparator arm	—	x	—	x	x
Color graphics	—	x	x	x	x
Touch screen operation	—	x	x	x	x
Operating system	—	MLX Android™	Windows®	MLX Android™	MLX Android™
X-Y-Q axis digital readout	x	x	x	x	x
2D geometry software with skew	—	x	x	—	x
Optical edge detection option	—	x	x	—	x
Software developer	—	MetLogix™	MetLogix™	MetLogix™	MetLogix™

OPERATOR INTERFACE- VB400

Feature	MetLogix™ M1	M2	Mx100	Mx200
Mounted to comparator arm	x	x	x	x
Color graphics	x	x	x	x
Touch screen operation	x	x	x	x
Operating system	MLX Android™	Windows®	MLX Android™	MLX Android™
X-Y-Q axis digital readout	x	x	x	x
2D geometry software with skew	x	x	—	x
Optical edge detection option	x	x	—	x
Software developer	MetLogix™	MetLogix™	MetLogix™	MetLogix™

SPECIFICATIONS

	VB300
Horizontal Travel	4" (100mm)
Vertical Travel	4" (100mm)
Focus Travel	3.5" (90mm)
Top Plate*	9" x 9" (225mm x 225mm)
Glass Insert	6" x 6" (150mm x 150mm)
Image	Reversed

*With machined slot for easy fixturing

SPECIFICATIONS

	VB400
Horizontal Travel	8" (200mm)
Vertical Travel	4" (100mm)
Focus Travel	4" (100mm)
Top Plate*	16" x 9" (400mm x 230mm)
Glass Insert	9-1/4" x 5-1/2" (235mm x 140mm)
Image	Reversed

*With machined slot for easy fixturing

WEIGHT AND DIMENSIONS

	VB300
Net Weight	423lbs 192kg
Shipping Weight	443lbs 201kg
Gross Dimensions (L x W x H)	44" x 33" x 52" (112cm x 84cm x 132cm)

WEIGHT AND DIMENSIONS

	VB400
Net Weight	423lbs 192kg
Shipping Weight	443lbs 201kg
Shipping Dimensions (L x W x H)	49" x 32" x 51" (125cm x 81cm x 130cm)

VB300 DIMENSIONS

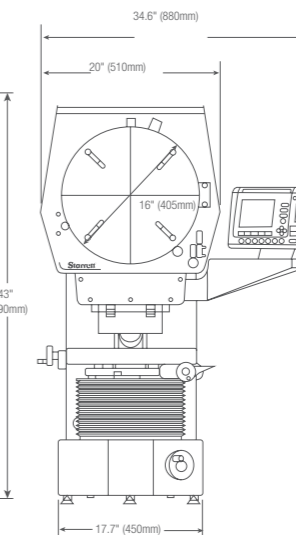
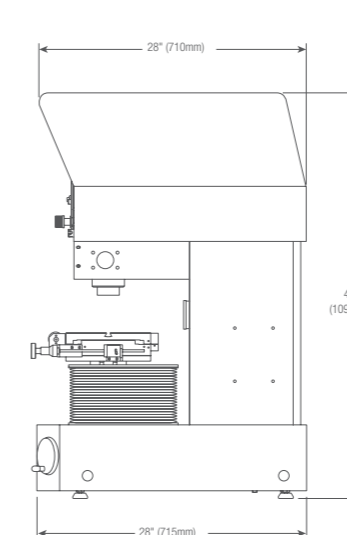
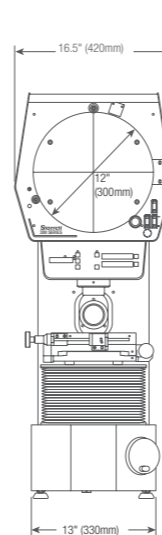

VB400 DIMENSIONS

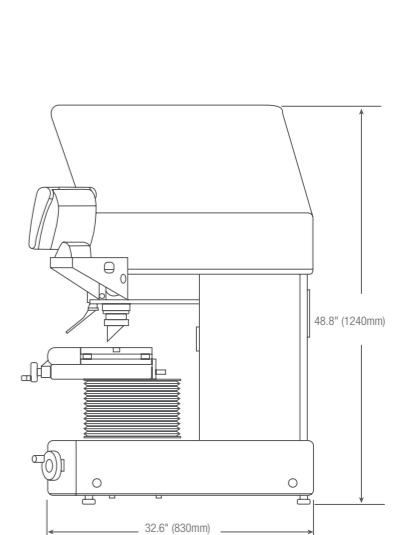

STARRETT PRODUCT LINES

Band Saw Blades

Force Measurement

Jobsite & Workshop Tools

Laser Measurement

Metrology Equipment

Precision Granite

Precision Ground Solutions

Precision Measuring Tools

PTA & Hand Tools

Service

Webber Gage Blocks

METROLOGY SYSTEMS



Follow us!



www.starrett-metrology.co.uk

Starrett®

Phone: 00 44 (0)1835 863501 | Email: Metrology@starrett.co.uk
Oxnam Road, Jedburgh TD8 6LR Scotland UK